



Combined instrument transformers

Outdoor operation
SF₆-gas insulated

EJGF (245 – 550) kV



PFIFFNER

Current and voltage – our passion



General description

Type EJGF combined transformers are used in high-voltage substations within the 245–550 kV range. They transfer high voltage and high current into standardised, equivalent values for meters, measuring and protection devices.

The voltage transformer component is located in the top of the pressure-resistant head housing and the current transformer cores at the bottom. In the current transformer unit, the iron core is set to high-voltage potential and the secondary windings to earth potential. The current transformer cores are fitted in a protective core shell made of massive cast aluminium, which is connected short-circuit proof to the bushing. The secondary outlets are passed through the SF₆/air bushing in the connection terminal box on the base support of the insulator.

The electrical field distribution along the insulator is optimised by a special layout of the control electrode inside the silicone composite insulator.

The housing components consist of helium-tight, corrosion-resistant cast aluminium. All housing components under pressure are individually type-tested according to applicable pressure vessel standards.

The SF₆ gas density is monitored by a temperature-compensated gas density monitor with alarm contacts. The special design means the function of the gas density monitor can be checked without dismantling it.

A corrosion-resistant metal rupture disc, protected by a metal cover, located at the top of the head housing ensures safe pressure relief in case of error.

The generously designed terminal box is equipped with a cover that opens sideways.

Pure SF₆ gas is used for ambient temperatures up to -40°C. The transformer is filled with a mixed gas for lower ambient temperatures up to -60°C.



Advantages of combined instrument transformers

- Reduced transport costs with one unit instead of two
- Less space needed with just one footprint
- Lower material costs due to a reduced number of supports and fewer primary connections
- Lower installation effort as only one unit has to be installed instead of two

Design

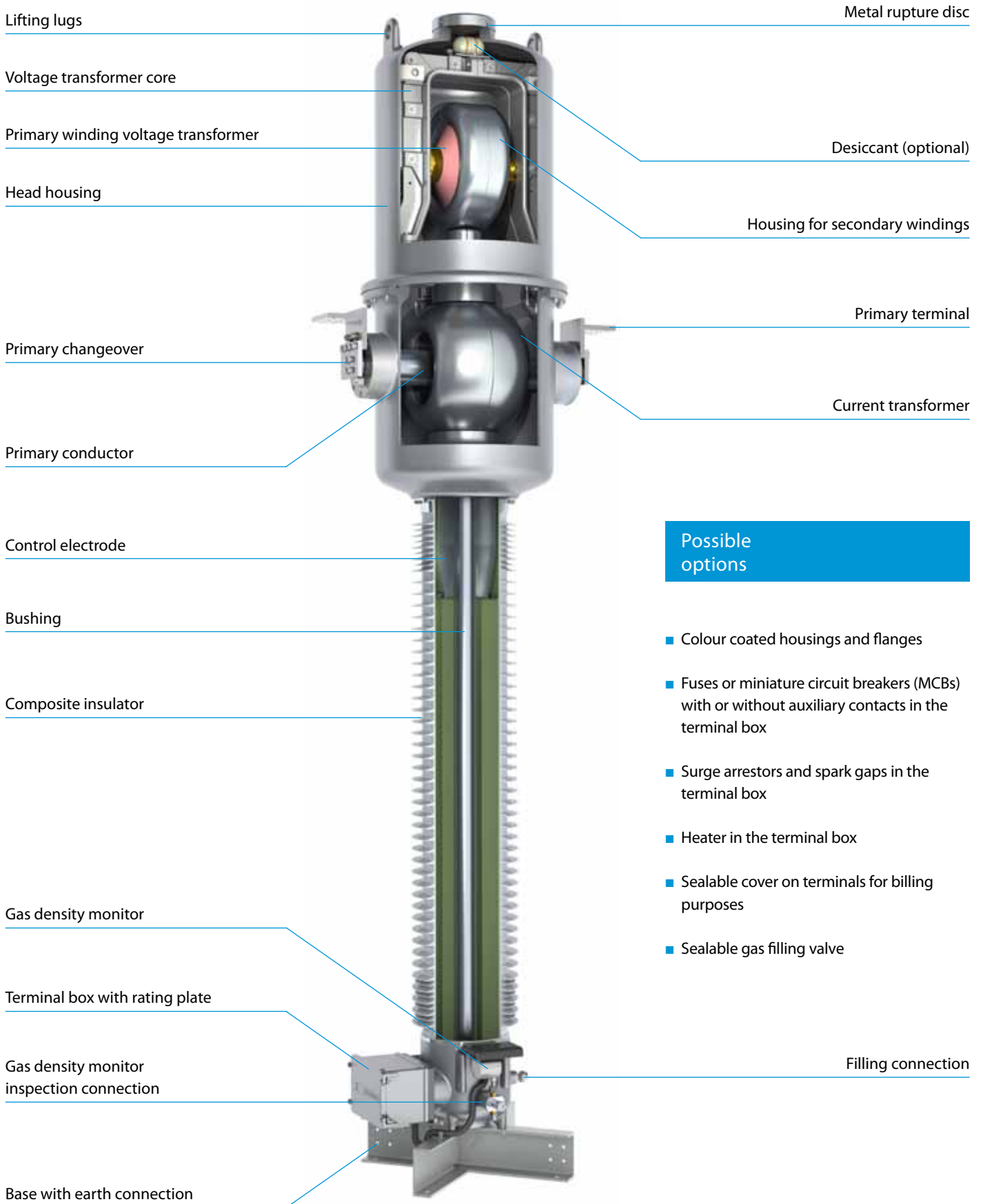

Technical data

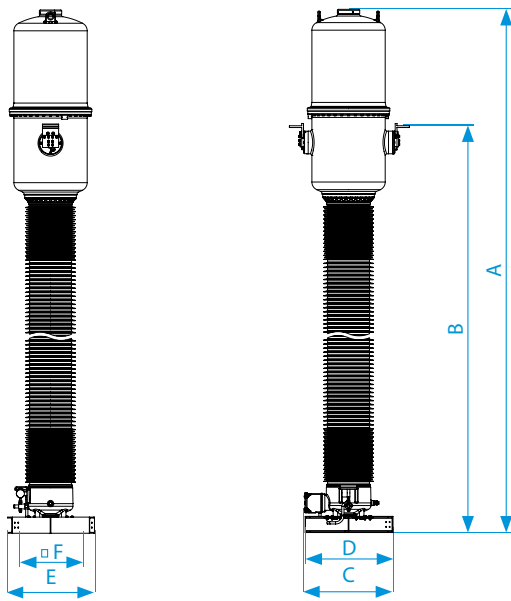

Type EJGF		245	300	330	362	420	550
Standard		IEC / IEEE					
Highest voltage for equipment	kV	245	300	330	363	420	550
Rated power-frequency withstand voltage	kV	460	460	460	575	630	680
Rated lightning impulse withstand voltage	kV	1050	1050	1175	1175	1425	1550
Frequency	Hz	50 / 60					
Primary rated current	A	≤ 5000					
Secondary rated current	A	1 / 5					
Rated short-time thermal current [I _{th}]	kA/3s	≤ 80					
Rated dynamic current [I _{dyn}]	kA	≤ 200					
Accuracy class CT part		0.1 – 3; P; PR; PX; TPS; TPX; TPY; TPZ					
Accuracy class VT part		0.1 – 3; 3P; 6P					
Rated thermal limiting output VT part	VA	≤ 3000					
Max. simultaneous burden (cl. 0.2)	VA	300					
Max. number of CT cores		8					
Max. number of VT windings		5					
Nominal operating / transport overpressure (20°C)	bar	4 / 0.5					

Type EJGF		245	300	330	362	420	550
Height of unit*	A mm	4980	4980	6140	6140	6500	7440
Height to primary terminal*	B mm	3375	3375	4730	4730	5090	5890
Depth of unit including terminal box	C mm	845	845	1088	1088	1088	1088
Depth of unit base	D mm	749	749	1088	1088	1088	1088
Width of unit base	E mm	736	736	1075	1075	1075	1075
Distance between screw holes at base	F mm	600	600	900	900	900	900
Min. creepage distance*	mm	6700	7500	8250	9050	10500	13750
Gross weight / gas weight, approx.*	kg	940 / 45	940 / 45	1000 / 58	1000 / 58	1600 / 60	1700 / 63

* with standard composite silicone insulator, creepage distance 25 mm/kV



Highlights



Easy primary changeover

- A clear and easy primary changeover with a ratio of 1:2 or 1:2:4 is available.
- The primary changeover is adjusted with one metal plate at each side of the head only.
- No need to dismantle or move the primary connections during adjustment.

Excellent protection against moisture

- The inner side of the instrument transformer is protected against moisture by means of special sealing rings.
- All housings are designed with a drain-age area to protect the sealing surfaces of the housings against rain. This significantly reduces crevice corrosion.
- The housing elements are connected with special stainless steel screws. They are designed in such a way that no humidity can enter the screw hole.

Installation-friendly terminal box

- The generously sized terminal box with a cover that can be opened sideways, is secured with captive screws. It can accommodate terminal blocks, fuses, surge arrestors, additional auxiliary contacts, spark gaps and sealable covers.
- The terminal box is equipped as standard with a blind flange. Cable glands can be installed on request.
- The terminal box has a protected ventilation aperture to prevent condensation.

Global presence

PIFFNER Instr. Transformers Ltd

5042 Hirschthal
Switzerland

☎ +41 (0)62 7392828
✉ sales@pmw.ch
💻 www.pfiffner-group.com/pch

PIFFNER Technologie Ltd

5042 Hirschthal
Switzerland

☎ +41 (0)62 7392828
✉ technologie@pmw.ch
💻 www.pfiffner-group.com/pte

PIFFNER Systems Ltd

4303 Kaiseraugst
Switzerland

☎ +41 (0)61 4676111
✉ info@pfiffner-systems.com
💻 www.pfiffner-systems.com

PIFFNER Deutschland GmbH

25524 Itzehoe
Germany

☎ +49 (0)48 21408270
✉ sales@pfiffner-messwandler.de
💻 www.pfiffner-group.com/pde

PIFFNER Transformatör A.S.

06750 Akyurt/Ankara
Turkey

☎ +90 (0)31 28475521
✉ info@pfiffner.com.tr
💻 www.pfiffner-group.com/ptr

PIFFNER do Brasil Ltda

88307-740 Itajaí
Brazil

☎ +55 (0)47 33481700
✉ pfiffner@pfiffner.com.br
💻 www.pfiffner-group.com/pbr

MGC Moser-Glaser Ltd

4303 Kaiseraugst
Switzerland

☎ +41 (0)61 4676111
✉ info@mgc.ch
💻 www.mgc.ch

ALPHA Elektrotechnik Ltd

2560 Nidau
Switzerland

☎ +41 (0)32 3328700
✉ mail@alpha-et.ch
💻 www.alpha-et.ch

This document has been drawn up with the utmost care. We cannot, however, guarantee that it is entirely complete, correct or up-to-date. ©Copyright PFIFFNER / Subject to change without notice 2017.04



PFIFFNER

Current and voltage – our passion

HV

HIGH VOLTAGE

MV

MEDIUM VOLTAGE

LV

LOW VOLTAGE