



# Capacitive voltage transformers

Outdoor operation  
Oil-paper insulated

ECF (72–550) kV



**PFIFFNER**

Current and voltage – our passion



## General description

Capacitive voltage transformers of type ECF are used in high-voltage switchgears from 72 to 550 kV. They transmit voltages to standardised, equivalent values for meters, measuring and protective devices.

The capacitive voltage transformer consists of one condenser unit and one electromagnetic measuring unit (EMU). The condenser unit is located in the insulator and consists of one capacitive mixed dielectric which is impregnated with insulation liquid. This active part is hermetically sealed to the outside. For volume compensation of the oil there is a stainless steel expansion bellows in the head section. The operating pressure can be visualized via a monitoring unit. Depending on customer specification, creepage distance or voltage level, the condenser unit consists of up to 3 parts. In order to avoid field distortions, a shielding electrode is used from a voltage level of 420 kV. A high-grade composite or porcelain insulator can be used as insulator. According to the contamination classes of common standards, different creepage distances can be selected.

The EMU is an inductive intermediate voltage transformer which is housed in the foot case of the transformer. It allows the safe transmission of measurement signals. A damping unit ensures increased safety

against relaxation oscillation. By using proven materials the voltage transformer is temperature- and accuracy stable over the entire service life. On request, the voltage transformer can be designed in such a way that it can be used as a coupling capacitor for carrier transmission in high-voltage lines.

All metallic housings and flanges consist of a special aluminium alloy and can be painted in various colours. The generously sized terminal box is equipped with a cover that is to be opened sideways. This allows for easy connection of secondary cables. The terminal box is equipped with a flange without holes. On request, cable glands or individual safety devices can be built in.



### Advantages of capacitive voltage transformers

- Cost-effective and reliable Design for high and very high voltages
- Expandable for the transmission of high-frequency signals (TFH)
- Fabrication-internal adjustment of the accuracy classes, no on-site adjustment is required
- Temperature- and accuracy stable over the entire service life
- Increased safety against relaxation oscillation due to damping unit

# Design

Primary connection

Metal expansion bellows

Porcelain or silicone composite insulator

High-voltage capacitor

Intermediate-voltage bushing

Inductive voltage matching transformer

Lifting lugs

Oil level indicator  
Electromagnetic unit

Terminal box  
with rating plate

Compensation reactor

Damping unit

Aluminium housing

Main earth connection

Oil drain valve

## Possible options

- Intermediate-voltage earthing switch
- Intermediate-voltage bushing for check measurement during maintenance
- Power-line-carrier protection – protective device with discharge reactor, overvoltage protection and earthing switch
- Fuses/overload protectors to protect secondary windings
- Secondary windings with taps
- Secondary terminals in bolt design
- Heater unit in terminal box
- Blind flange for the insertion of the secondary cable equipped with cable glands

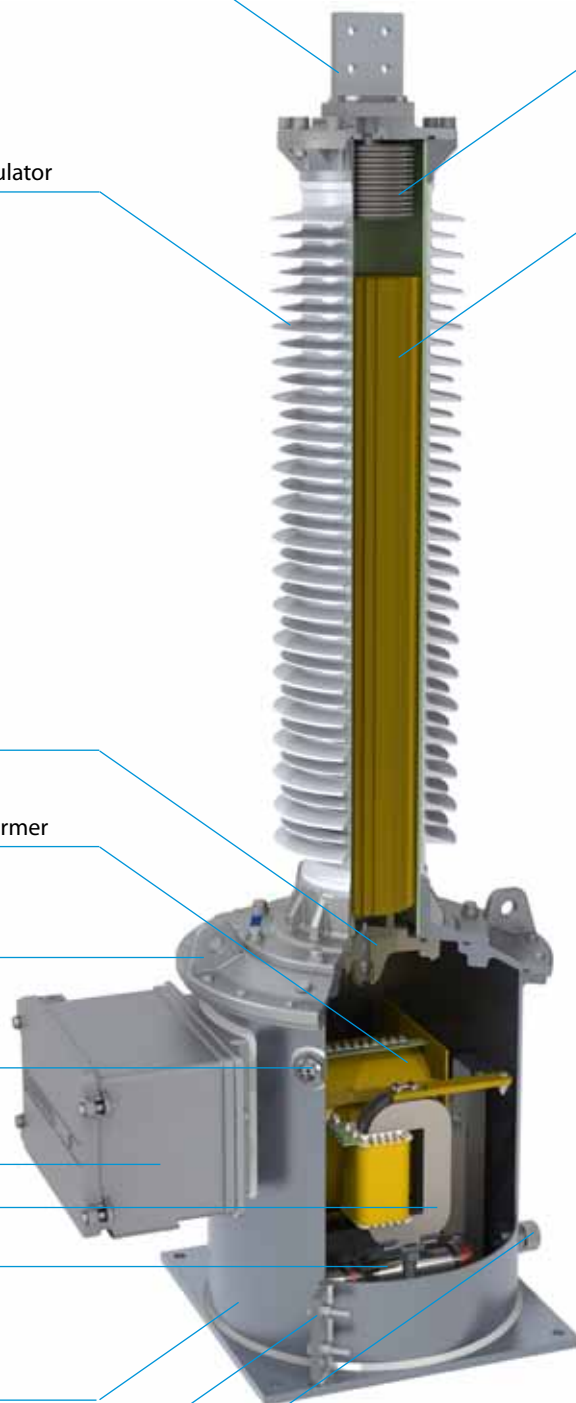

# Technical data

123 – 245 kV

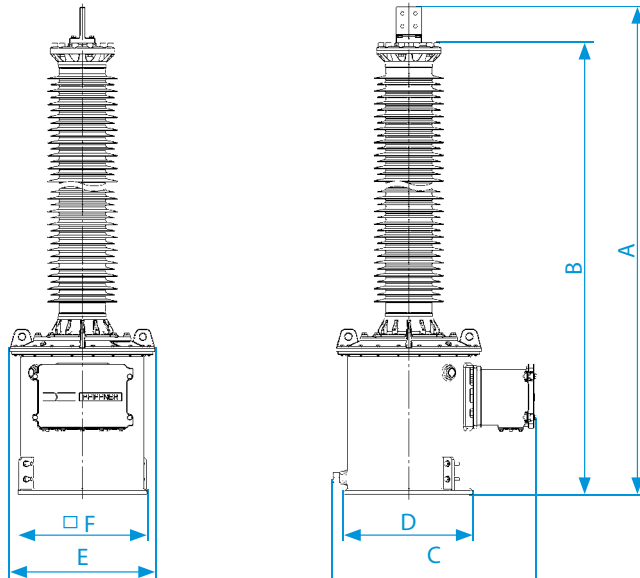

300 – 550 kV

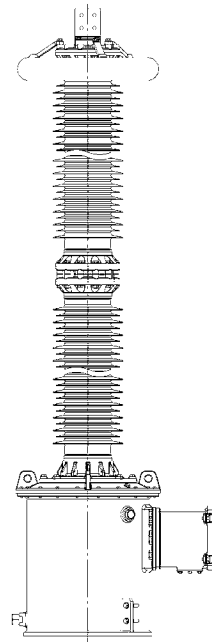

Type ECF		72	123	145	170	245	300	362	420	550
Standard		IEC / IEEE								
Highest voltage for equipment	kV	72.5	123	145	170	245	300	362	420	550
Rated power-frequency withstand voltage	kV	140	230	275	325	460	460	510	630	680
Rated lightning impulse withstand voltage	kV	325	550	650	750	1050	1050	1175	1425	1550
Frequency	Hz	50/60								
Accuracy class		0.1 – 3; 3P; 6P								
Rated thermal limiting output	VA	≤ 1000								
Max. simultaneous burden (cl. 0.2)	VA	150								
Max. number of VT windings		5								

Type ECF		72	123	145	170	245	300	362	420	550
Height of unit*	A mm	1660	1930	2130	2330	2930	3310	3510	4310	5110
Height to primary terminal*	B mm	1520	1790	1990	2190	2790	3170	3370	4170	4970
Depth of unit including terminal box	C mm	746	746	746	746	746	746	746	746	746
Depth of unit base	D mm	500	500	500	500	500	500	500	500	500
Width of unit base	E mm	500	500	500	500	500	500	500	500	500
Distance between screw holes at base	F mm	450	450	450	450	450	450	450	450	450
Min. creepage distance*	mm	2420	3540	4280	5030	7260	7820	8560	11540	14520
Approximate weight*	kg	280	300	320	340	400	420	450	500	540

\* with standard composite silicone insulator, creepage distance 25 mm/kV



## Highlights

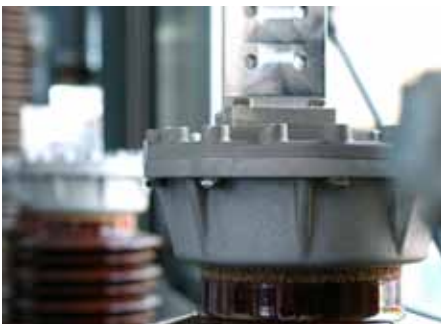

### High and very high voltage

- Simple and safe mounting on site for transformers which consist of multi-piece condenser units
- High temperature and precision stability over the entire service life
- Compensation of transient overvoltages in the grid, caused by circuit breakers



### Tone frequency (PLC) couplings

- Expandable for high frequency signal (PLC) couplings
- Extendable for the installation of a line trap coil



### Easy-to-fit terminal box

- The terminal box with the lid to be opened sideways is secured by captive screws. Apart from terminals, fuses, surge arresters, additional contacts, spark gaps and sealable covers can be built in.
- By default, the terminal box is equipped with a blind flange.
- On request, the capacitive voltage transformer can be equipped with an additional terminal box.

# Global presence

## PIFFNER Instr. Transformers Ltd

5042 Hirschthal  
Switzerland

☎ +41 (0)62 7392828  
✉ sales@pmw.ch  
💻 www.pfiffner-group.com/pch

## PIFFNER Technologie Ltd

5042 Hirschthal  
Switzerland

☎ +41 (0)62 7392828  
✉ technologie@pmw.ch  
💻 www.pfiffner-group.com/pte

## PIFFNER Systems Ltd

4303 Kaiseraugst  
Switzerland

☎ +41 (0)61 4676111  
✉ info@pfiffner-systems.com  
💻 www.pfiffner-systems.com

## PIFFNER Deutschland GmbH

25524 Itzehoe  
Germany

☎ +49 (0)48 21408270  
✉ sales@pfiffner-messwandler.de  
💻 www.pfiffner-group.com/pde

## PIFFNER Transformatör A.S.

06750 Akyurt/Ankara  
Turkey

☎ +90 (0)31 28475521  
✉ info@pfiffner.com.tr  
💻 www.pfiffner-group.com/ptr

## PIFFNER do Brasil Ltda

88307-740 Itajai  
Brazil

☎ +55 (0)47 33481700  
✉ pfiffner@pfiffner.com.br  
💻 www.pfiffner-group.com/pbr

## MGC Moser-Glaser Ltd

4303 Kaiseraugst  
Switzerland

☎ +41 (0)61 4676111  
✉ info@mgc.ch  
💻 www.mgc.ch

## ALPHA Elektrotechnik Ltd

2560 Nidau  
Switzerland

☎ +41 (0)32 3328700  
✉ mail@alpha-et.ch  
💻 www.alpha-et.ch

This document has been drawn up with the utmost care. We cannot, however, guarantee that it is entirely complete, correct or up-to-date. ©Copyright PFIFFNER / Subject to change without notice 2017.04



# PFIFFNER

Current and voltage – our passion

HV

HIGH VOLTAGE

MV

MEDIUM VOLTAGE

LV

LOW VOLTAGE