



DURESCA®

DTOIA(S) Condenser bushings, 25 - 345kV

Transformer to Air with Dry-type insulation, RIP or RIS
IEEE Standards C57.19.01-2017 and C57.19.00-2004

 **MOSER GLASER**

Current and voltage – our passion

Swiss quality combined with global experience



Features

Dry-type RIP Insulation

Moser Glaser researched a way to increase the dielectric characteristics of its High Voltage equipment. As a result Moser Glaser invented the Epoxy Resin Impregnated Paper (RIP) technology in 1958.

With more than 50 years of experience in development of the RIP technology, Moser Glaser offers transformer bushings DURESCA® DTOIA from 25 to 345kV.

The insulation lays directly on the conductor or tube and consists of crepe paper dried under vacuum and impregnated with epoxy resin. Conductive grading layers are embedded during the winding of the insulation for the best field control. This guarantees the highest operational and human safety.

A strong moisture barrier prevents any contamination or moisture ingress.

Moser Glaser design does not use any oil; DTOIA are completely dry and free of partial discharge.

DTOIA bushings can be applied at any position from 0° to 90° from vertical and allow for safe horizontal transport and storage.

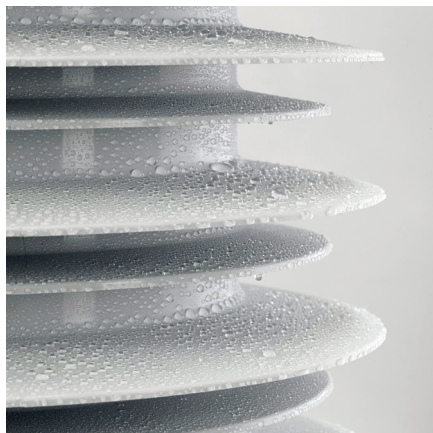

Silicone housing

Moser Glaser pioneered the standardization of Silicone Rubber Insulators on Bushings, bringing a high level in safety and reliability to the Electric Utility industry and increasing the performance of the bushing in heavily polluted environments.

Weight reduced as well as flexible sheds, increase its tolerance to vandalism, or earthquakes. No risk of porcelain break during shipping or handling; no collateral damage.

Moser Glaser standardized on a minimum 54mm/kV of nominal line-to-ground voltage creepage distance.

Replacement bushings

Moser Glaser can interchange a wide variety of bushings designs. This allows the customer to replace existing OIP bushings with the RIP technology. The supply chain is simplified as the silicone molding operation is done in-house, Moser Glaser can offer short lead-times for its standard range of product.

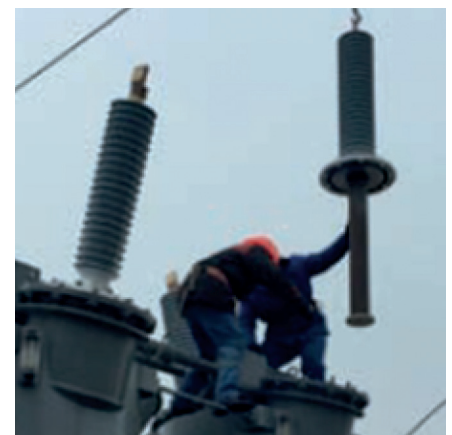

DTOIA bushings are also available with RIS (Resin Impregnated Synthetic) insulation.

The main performance and life expectancy restraint in RIP condenser bushings was found to be the paper itself. Paper is an organic material with inconsistent material parameters, namely the moisture content. Too much moisture will cause high loss values, degrade the insulation system of the bushing, and possibly cause a premature failure. In order to compensate this, modern RIP bushings utilize drying systems during the manufacturing process.

For shipment and storage, plastic bags with a dessicate bag or oil containers are used to protect the bushing. Finding an alternative material to paper was not an easy task, though, due to the fact that paper provides good insulation characteristics and has been used in bushing and transformer manufacturing processes for many years with continual optimization.

Several experimentations were needed to find optimal successor.

Moser Glaser undertook this task by performing tests on many materials in order to find a successor to the paper. After research, Moser Glaser found a special polyester structural material which is an excellent alternative to paper. Moser Glaser performed a sequence of tests to qualify this solution:



Routine and type tests according to IEC 60137-ed7.0 and IEEE C57.19.00-2004 Specifications for the type tests were beyond the requirements of the standard.

In addition several special tests have been developed to challenge this solution.

- Adhesion test of direct moulded silicone on the RIS insulation
- Special humidity test
- Dynamic cantilever load tests
- Temperature cycle test
- Accelerated ageing test under high voltage

The new Resin Impregnated Synthetic RIS is now developed and part of Moser Glaser products portfolio.

An all-inclusive solution!

The result of this development is an ideal association of existing epoxy resin technology and its appreciated characteristics...

- Partial discharge free
- Installation at any angle
- Self-extinguish material (no risk of fire)

enhanced with new features:

- Shorter production cycle
- Easier handling for long transportation and storage
- Reduced power factor and capacitance
- Not affected by humidity

For outdoor application Moser Glaser standardized a direct-moulded silicone insulator to provide an even more safer solution.

Moser Glaser could maintain its strength by providing a high level of customization.

Therefore RIS technology can be applied to the standard range and also can interchange all existing designs. There are no limitation as for the diameter and length.

What you get today with RIP technology can be offered with RIS.

With this important new milestone, Moser Glaser is now ready to offer the bushing of the future.



Cut from a RIS active part



Cut from an RIP active part

Design

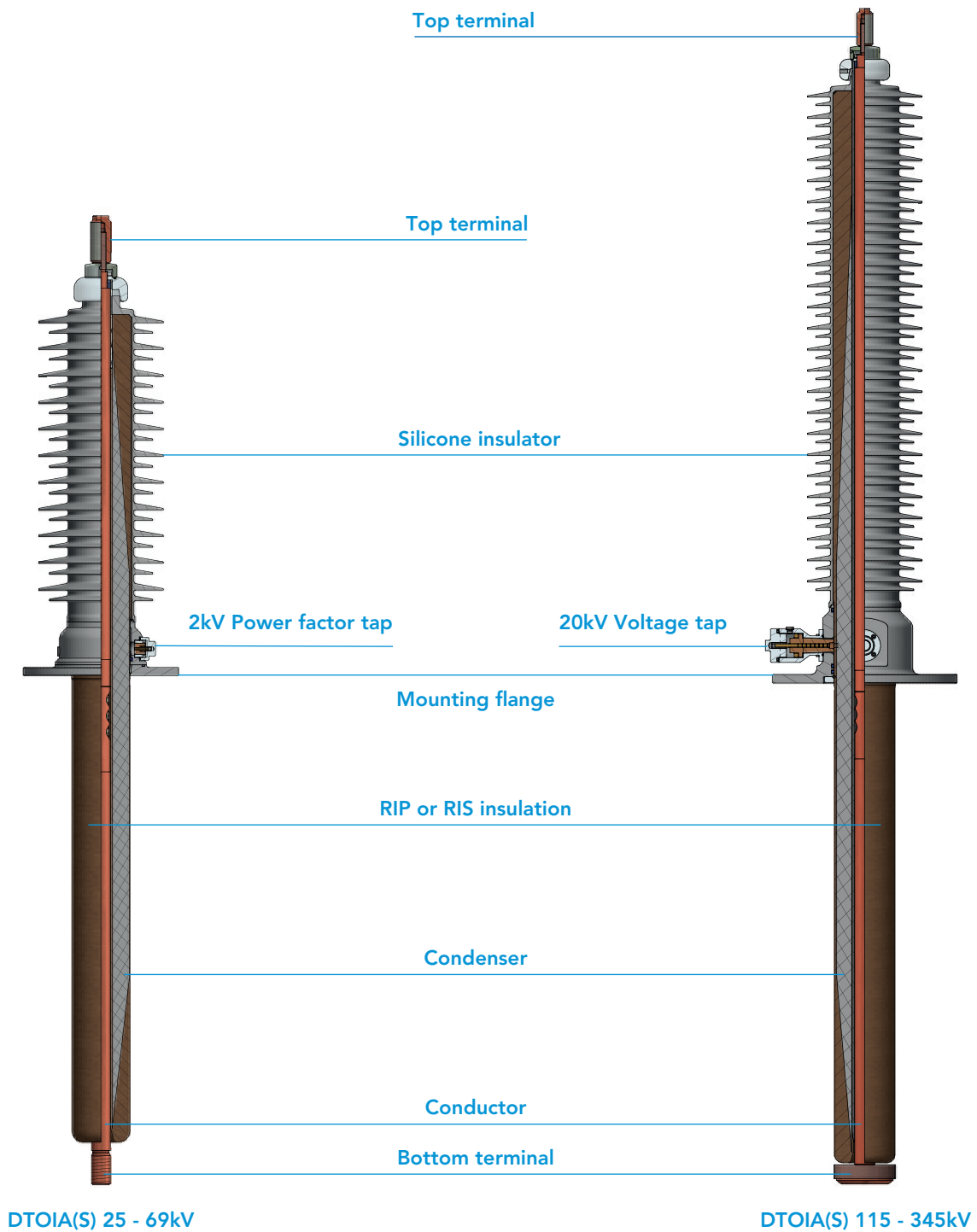

All technical data (electrical and dimensions) from this catalogue are applicable for RIP as well as RIS insulation.

- Bushings with RIP insulation are denominated as DTOI
- Bushings with RIS insulation as DTOIS

Common characteristics

Top terminal

- DTOIA(S) bushings are delivered with a top terminal in copper silver plated. It's bolted to the head of the bushing for the Draw-lead and Draw-rod type or part of the conductor for the Fix-conductor type.
- NEMA top terminal pad can be offered as an optional accessory.

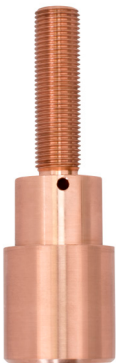

Draw-lead

The maximum continuous current rating of the Draw-lead cable is determined by the size and type of the cable supplied by the transformer manufacturer.

- Moser Glaser offers various possibilities of Draw-lead connectors to ensure a full interchangeability in case of bushing replacement.
- DTOIA(S) Draw-lead bushings do not require additional shielding up to 161kV.
- The right selection of the cable size is the responsibility of the transformer manufacturer.
- The Draw-lead has to be insulated to isolate it from the bushing center tube.
- More details are given on page 8.

Draw-rod

- Moser Glaser offers extended bushing flexibility and ease-of-use through the use of a Draw-rod conductor.
- A split copper rod allows easy installation and removal without lowering the oil level, while also providing current ratings beyond draw-lead ratings.

Short-time current level

- The bushings withstand a short-time current of 25x rated continuous current for a maximum of 2 seconds.
- For Draw-lead the short-time current is defined according to the cable cross section in mm²:
 $I_{th\ 2sec\ (kA)} = 0.06 \times S$

Current

- The current rating gives the maximum continuous rating with no effect on the bushing life time.
Draw-lead; 800A
Draw-rod; 1200A (up to 161kV)
Bottom connected; 2000A and above
- Bushing rating as well as cable size has to be chosen at least 20% above transformer rating.

Bottom connected

- Used for bushings with the highest current ratings. A man-hole on the transformer is required to access the connection.
- The bushing can be equipped with a removable corona shield as an optional accessory.

Mounting flange

Made of corrosion free aluminium, equipped with

- Lifting holes
- Power factor tap (all ratings)
- Voltage tap (for 115kV and above)



Power factor, Voltage taps

- All bushings have a Power factor tap. The tap is connected to the ground layer.
- The grounding is done through the cap. Test voltage is 2kV, 50Hz for 72sec.
- 115kV and above are additionally equipped with a 20kV Voltage tap. It's connected to one of the inner layer from the C1 condenser.

Solutions for Draw-lead connectors

Connection through brazing

The Draw-lead connector is equipped with a pilot hole. It has to be drilled according to the lead diameter. Maximum cable section is 400mm² up to 161kV and 500mm² for 230kV. The cable is connected to the Draw-lead connector via brazing and draw through the bushing center tube. Maximum current rating is 800A.

➤ When no information is given to Moser Glaser, this one will be the default choice.

Part number will be the drawing number with the extension .B01
Ex.: 600.17.0004.B01 for a DTOIA 25kV – 800A

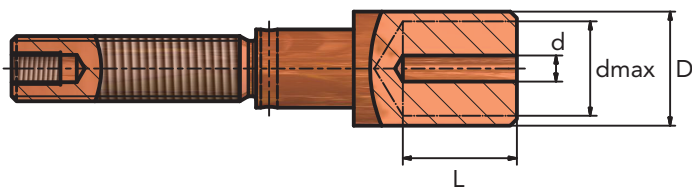

DTOIA(S)	D	d	d max	L
25 to 69kV	1.38"	0.31"	1.14"	1.38"
115 to 161kV	1.89"	0.31"	1.57"	1.38"
230 to 345kV	2.36"	0.31"	2.05"	1.38"

Connection through brazing on a spade

Alternative brazed solution is offered for Draw-lead bushings.

The apparatus cable is directly brazed on the Draw-lead connector spade. Maximum current rating is 400A up to 69kV and 800A for 115kV and above.

Part number will be the drawing number with the extension .B31
Ex.: 600.17.0007.B31 for a DTOIA 34.5kV – 400A

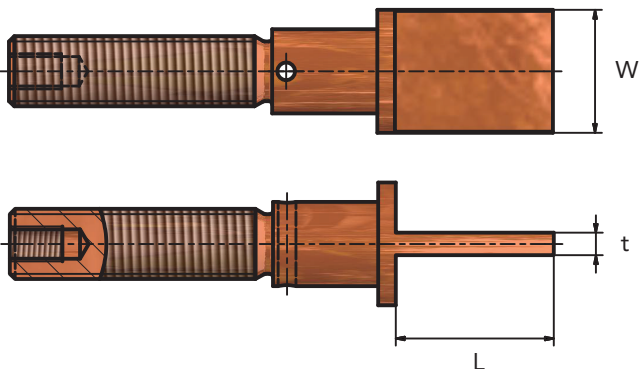

DTOIA(S)	W	t	L
25 to 69kV	1.38"	0.25"	1.77"
115 to 161kV	1.89"	0.25"	1.77"
230 to 345kV	2.36"	0.25"	1.77"

Connection through crimping

The connector is adapted to Draw-lead size. Maximum current rating is 400A.

Part number will be the drawing number with the extension .B21 to .B25
Ex.: 600.17.0013.B25 for a DTOIA 69kV – 400A

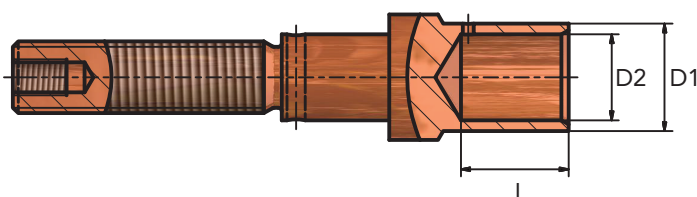

DTOIA(S)	Extension	D1	D2	L
25 to 345kV	.B21	0.570"	0.433"	1.18"
	.B22	0.669"	0.510"	1.18"
	.B23	0.787"	0.590"	1.18"
	.B24	1.060"	0.750"	1.18"
	.B25	1.181"	0.945"	1.18"

Replacing Draw-lead bushings

The most critical parameter to consider is the height above the flange of the existing bushing versus the replacement bushing. Below two solutions are then offered:

1. When the air side of the bushing is longer than the existing bushing

Moser Glaser offers lengthened Draw-lead connector (for brazing or crimping) to compensate any difference in the length of the cable. When the customer wants to keep the existing configuration, Moser Glaser offers an adapter that threads onto the existing Draw-lead stud.

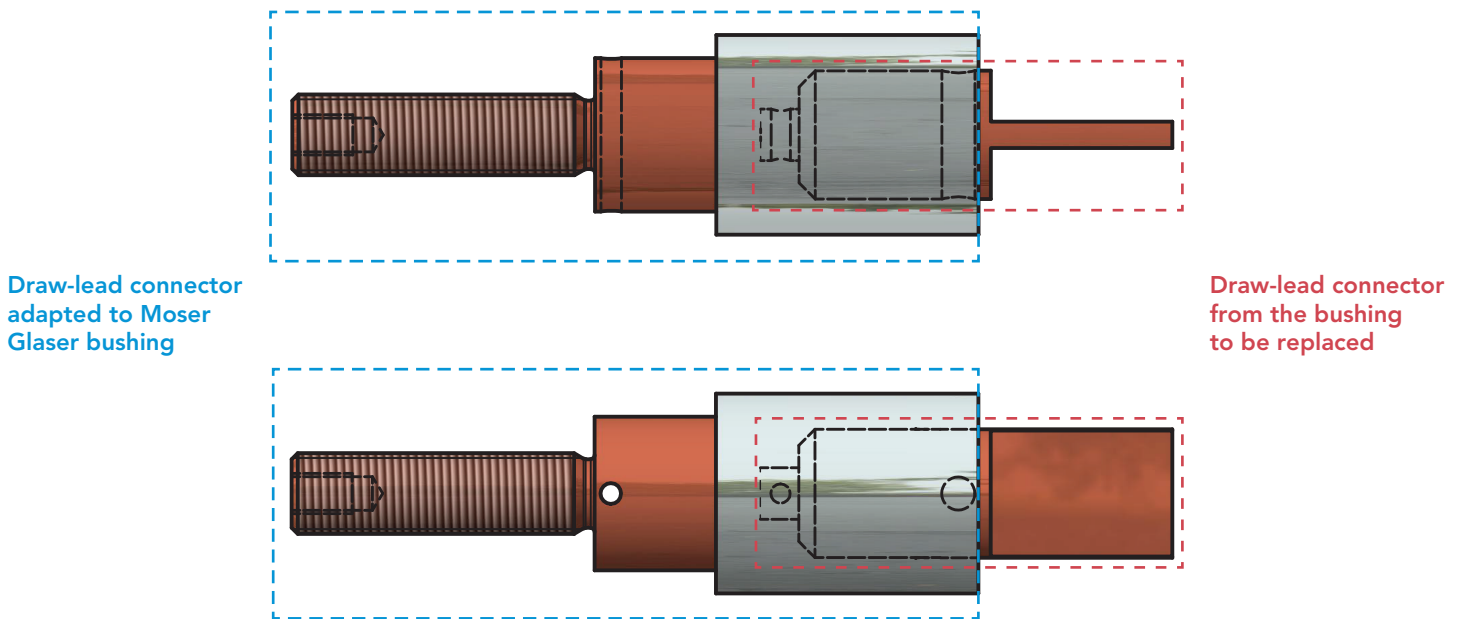

It is a quick and easy solution to correct the difference in height and avoid any additional brazing or crimping operation on-site. Ask Moser Glaser for more details about this solution.

2. When the air side of the bushing is shorter than the existing bushing

This is a more complicated procedure requiring that the original Draw-lead connector has to be cut off at a specific point on the Draw-lead cable and either crimping or brazing on a new one.

Thanks to its flexible manufacturing equipment, Moser Glaser can offer Draw-lead bushings with an extended strike distance and therefore compensate the air side length difference.

Then this bushing can be equipped with a Draw-lead adapter as presented in the solution 1 or a standard connector.

Dimensions 25 - 69kV

Draw-lead

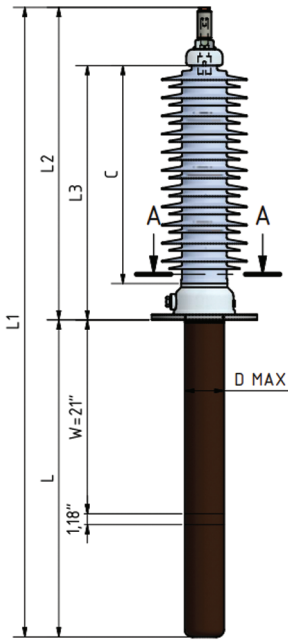

Capable to carry up to 800A by cable

Bottom Terminal Threaded Draw-rod

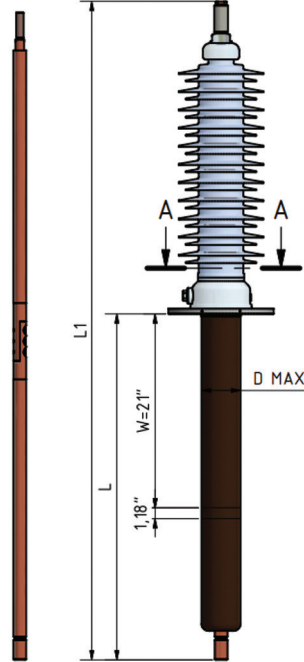

The Draw-lead type bushing is equipped with a Draw-rod to increase the current to 1200A

Bottom Terminal Flat Fix-conductor

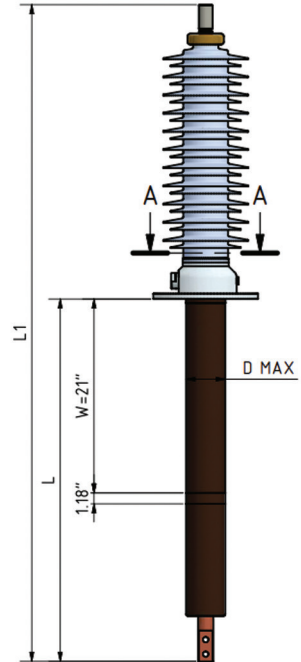

The conductor is fix type for ratings $\geq 2000A$

Flange A-A

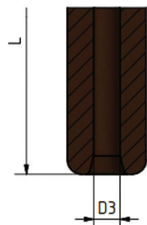
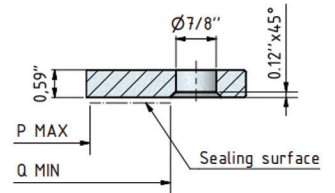
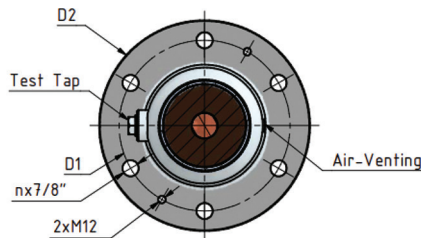
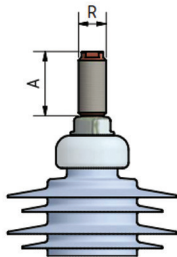

Fig. 1

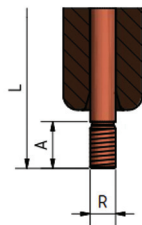

Fig. 2

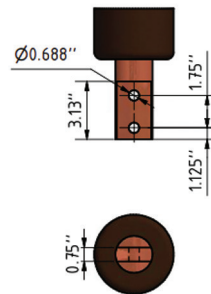

Fig. 2.4

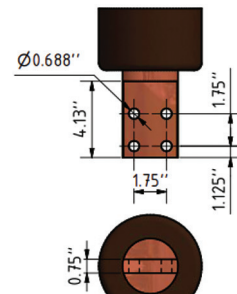

Fig. 2.5

Standard ratings

Rating	Nominal system voltage		34.5				46				69					
	kV	25														
	BIL		200				250				350					
	Line to ground voltage		22				29				160					
	Max. rated continuous current		800*				1200				2000					
Design		Draw-lead	Bottom Terminal Threaded Draw-rod	Bottom Terminal Flat Fix-conductor	Bottom Terminal Flat Fix-conductor	Draw-lead	Bottom Terminal Threaded Draw-rod	Bottom Terminal Flat Fix-conductor	Bottom Terminal Flat Fix-conductor	Draw-lead	Bottom Terminal Threaded Draw-rod	Draw-lead	Bottom Terminal Threaded Draw-rod	Bottom Terminal Flat Fix-conductor	Bottom Terminal Flat Fix-conductor	
	Overall length	mm	1255	1310	1330	1381	1355	1410	1432	1411	1506	1561	1757	1812	1813	1813
(in)		49.4	51.57	52.36	54.37	53.34	55.51	56.38	55.55	59.28	61.46	69.18	71.34	71.38	71.38	
Length above flange (L2)	mm	560	560	510	510	610	610	560	560	710	710	860	860	810	810	
	(in)	22	22	20.08	20.08	24.02	24.02	22.05	22.05	27.95	27.95	33.86	33.86	31.89	31.89	
Arcing distance (C)	mm	300	300	300	300	350	350	350	350	450	450	600	600	600	600	
	(in)	11.81	11.81	11.81	11.81	13.78	13.78	13.78	13.78	17.72	17.72	23.61	23.62	23.62	23.62	
Draw lead length (L3)	mm	380				430				530		680				
	(in)	14.96				16.93				20.87		26.77				
Bottom end	Oil end length (L)	mm	695	750	820	871	745	800	872	851	796	851	897	952	1003	1003
		(in)	27.36	29.53	32.28	34.29	29.33	31.5	34.3	33.5	31.33	33.5	35.31	37.5	39.49	39.49
CT Pocket (W)	mm	534	534	534	534	534	534	534	534	534	534	534	534	534	534	
	(in)	21	21	21	21	21	21	21	21	21	21	21	21	21	21	
Oil side diameter (D MAX)	mm	80	80	80	109	80	80	80	111	80	80	80	80	111	141	
	(in)	3.15	3.15	3.15	4.29	3.15	3.15	3.15	4.29	3.15	3.15	3.15	3.15	4.29	5.55	
Tube	Inside tube diameter (D3)	mm	35.7				35.7				35.7		35.7			
		(in)	1.41				1.41				1.41		1.41			
Top terminal	Usable thread (A) min.	mm	76	76	76	76	76	76	76	76	76	76	76	76	76	
		(in)	2.5	2.5	2.5	2.5	2.5	2.5	2.5	2.5	2.5	2.5	2.5	2.5	2.5	
	Thread class UN(F)-2A (R)	(in)	(1.5)-12	(1.5)-12	(2)-12	(3)-12	(1.5)-12	(1.5)-12	(2)-12	(3)-12	(1.5)-12	(1.5)-12	(1.5)-12	(1.5)-12	(2)-12	(3)-12
Bottom terminal	Type		1	2	2.4	2.4	1	2	2.4	2.5	1	2	1	2	2.4	2.5
	Usable thread (A) min.	mm		76				76				76		76		
		(in)		2.5				2.5				2.5		2.5		
	Thread class UN(F)-2A (R)	(in)		(1.5)-12				(1.5)-12				(1.5)-12		(1.5)-12		
Flange gasket space	Inside diameter (P MAX)	mm	120	120	120	150	120	120	120	150	120	120	120	120	150	180
		(in)	4.72	4.72	4.72	5.91	4.72	4.72	4.72	5.9	4.72	4.72	4.72	4.72	5.91	7.09
	Outside diameter (Q MIN)	mm	155	155	205	205	155	155	205	205	180	180	205	205	205	232
		(in)	6.1	6.1	8.07	8.07	6.1	6.1	8.07	8.07	7.1	7.1	8.07	8.07	8.07	9.13
Flange bolting details	No. Of bolts		4	4	6	6	4	4	6	6	4	4	6	6	6	
		Hole size	mm	22.2	22.2	22.2	22.2	22.2	22.2	22.2	22.2	22.2	22.2	22.2	22.2	22.2
		(in)	0.875	0.875	0.875	0.875	0.875	0.875	0.875	0.875	0.875	0.875	0.875	0.875	0.875	
	Bolt circle diameter (D1)	mm	184.2	184.2	235	235	184.2	184.2	235	235	209.6	209.6	235	235	235	260.4
		(in)	7.25	7.25	9.25	9.25	7.25	7.25	9.25	9.25	8.25	8.25	9.25	9.25	9.25	10.25
	Flange outside diameter (D2)	mm	225	225	290	290	225	225	290	290	250	250	290	290	290	335
(in)		8.86	8.86	11.42	11.42	8.86	8.86	11.42	11.42	9.84	9.84	11.42	11.42	11.42	13.19	
Weight	kg	15	24	39	78	16	26	42	80	18	39	21	46	66	138	
	lbs	33	52	88	169	34	54	91	177	29	63	34	75	118	285	

* Refer to the ordering number for the Draw-lead connector and its maximum current rating

Dimensions 115 - 345kV

Draw-lead

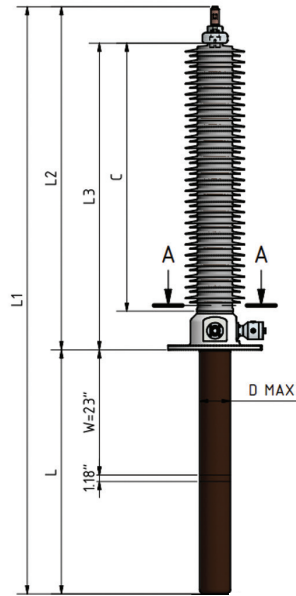

Capable to carry up to 800A by cable

Bottom connected
Fix-conductor

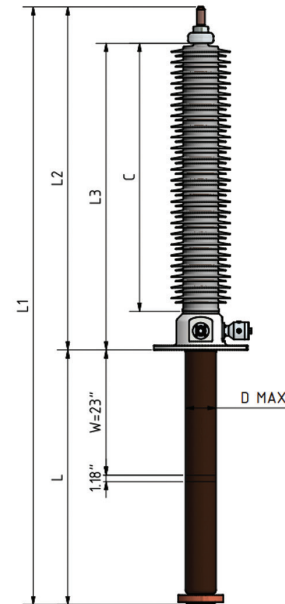

The conductor is fix type

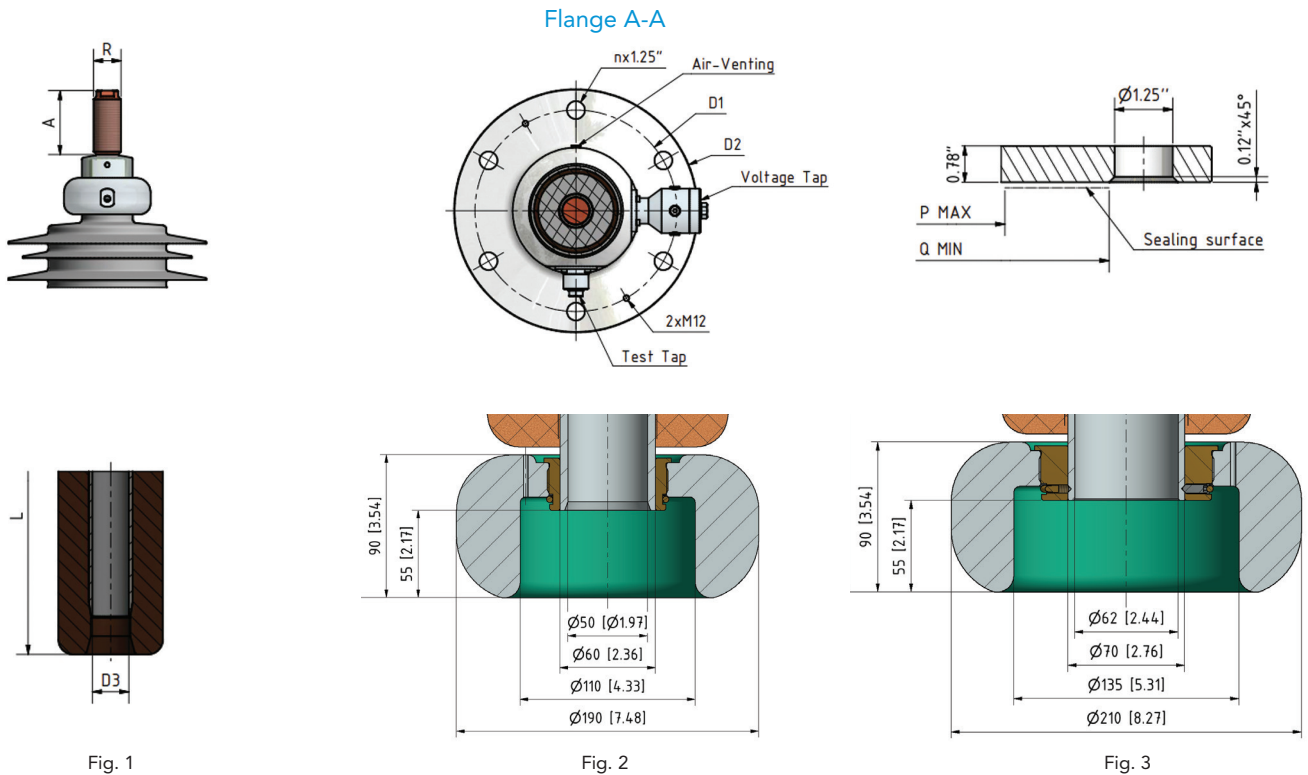

Fig. 1

Fig. 2

Fig. 3

See page 16 for terminals 3(e) and 3(f)

Standard ratings

Rating			115				138				161		230			345	
	Nominal system voltage	kV	115				138				161		230			345	
	BIL	kV	550				650				750		900			1175	
	Line to ground voltage	kV	88				102				102		146			220	
	Max. rated continuous current	A	800*	1200	2000	3000	800*	1200	2000	3000	800*	2000	800*	2000	3000	800*	2000
	Design		Draw-lead	Bottom Connected	Bottom Connected Fix-conductor	Bottom Connected Fix-conductor	Draw-lead	Bottom Connected	Bottom Connected Fix-conductor	Bottom Connected Fix-conductor	Draw-lead	Bottom Connected Fix-conductor	Draw-lead	Bottom Connected Fix-conductor	Bottom Connected Fix-conductor	Draw-lead	Bottom Connected Fix-conductor
	Overall length	mm	2432		2432	2432	2728		2728	2728	3016	3026	3376	3376	3376	4205	4145
		(in)	95.75		95.75	95.75	53.15		107.4	107.4	59.1	119.13	132.92	132.91	132.91	165.55	163.19
	Length above flange (L2)	mm	1400		1340	1340	1600		1540	1540	1800	1750	2160	2100	2100	2910	2850
		(in)	55.12		52.76	52.76	62.99		60.63	60.63	70.87	68.9	85.04	82.68	82.68	114.57	112.2
	Arcing distance (C)	mm	1050		1050	1050	1250		1250	1250	1450	1450	1810	1810	1810	2560	2560
		(in)	41.34		41.34	41.34	49.21		49.21	49.21	57.09	57.09	71.26	71.26	71.26	100.79	100.79
	Draw lead length (L3)	mm	1215				1415				1615		1975			2760	
		(in)	47.83				55.71				63.58		77.76			106.66	
Bottom end	Oil end length (L)	mm	1032		1092	1092	1128		1188	1188	1216	1276	1216	1276	1276	1295	1295
		(in)	40.63		42.99	42.99	44.41		46.77	46.77	47.88	50.24	47.88	50.24	50.24	51	50.98
	CT Pocket (W)	mm	584		584	584	584		584	584	584	584	584	584	584	584	584
		(in)	23		23	23	23		23	23	23	23	23	23	23	23	23
	Oil side diameter (D MAX)	mm	141		141	190	141		141	190	190	190	190	190	246	246	246
		(in)	5.55		5.55	7.48	5.55		5.55	7.48	7.48	7.48	7.48	7.48	9.69	9.69	9.69
Tube	Inside tube diameter (D3)	mm	50				50				50		62			62	
		(in)	1.97				1.97				1.97		2.44			2.44	
Top terminal	Usable thread (A) min.	mm	76		76	76	76		76	76	76	76	76	76	76	246	76
		(in)	2.5		2.5	2.5	2.5		2.5	2.5	2.5	2.5	2.5	2.5	2.5	9.69	2.5
	Thread class UN(F)-2A (R)	(in)	(1.5)-12		(2)-12	(3)-12	(1.5)-12		(2)-12	(3)-12	(1.5)-12	(2)-12	(1.5)-12	(2)-12	(3)-12	(1.5)-12	(2)-12
Bottom terminal	Type		1		3(e)	3(e)	1		3(e)	3(e)	1	3(e)	2	3(e)	3(e)	3	3(f)
	Usable thread (A) min.	mm															
		(in)															
	Thread class UN(F)-2A (R)	(in)															
Flange gasket space	Inside diameter (P MAX)	mm	180		180	240	180		180	276	314	314	225	225	435	380	380
		(in)	7.09		7.09	9.45	7.09		7.09	10.87	12.36	12.36	8.86	8.86	17.13	14.96	14.96
	Outside diameter (Q MIN)	mm	297		297	297	297		320	324	362	362	495	495	495	495	495
		(in)	11.69		11.69	11.69	11.69		12.6	12.8	14.25	14.25	19.49	19.49	19.49	19.49	19.49
Flange bolting details	No. Of bolts		6		6	6	6		6	6	8	8	12	12	12	12	12
	Hole size	mm	32		32	32	32		32	32	32	32	32	32	32	32	32
		(in)	1.26		1.26	1.26	1.26		1.26	1.26	1.26	1.26	1.26	1.26	1.26	1.26	1.26
	Bolt circle diameter (D1)	mm	336.5		336.5	336.5	362		362	362	400	400	533.4	533.4	533.4	533.4	533.4
		(in)	13.25		13.25	13.25	14.25		14.25	14.25	15.75	15.75	21	21	21	21	21
	Flange outside diameter (D2)	mm	425		425	425	437		437	437	450	450	597	597	597	597	597
		(in)	16.73		16.73	16.73	17.2		17.2	17.2	17.72	17.72	23.5	23.5	23.5	23.5	23.5
Weight		kg	80		131	272	90		148	307	161	277	184	318	499	368	534
		lbs	176		289	594	198		325	672	327	623	394	700	1096	812	1192

* Refer to the ordering number for the Draw-lead connector and its maximum current rating

Bottom terminal 3(e)

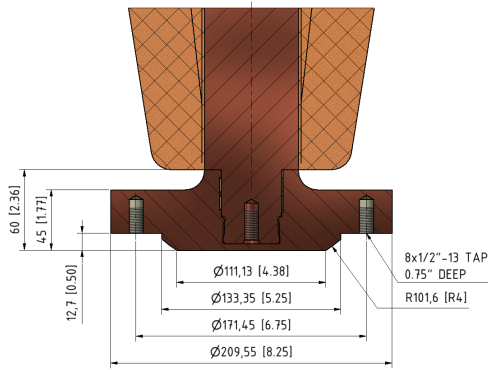

Bottom terminal 3(e)

+ optional flat pad terminal and electrode shield

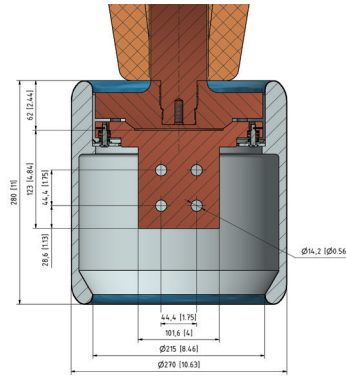

Bottom terminal 3(f)

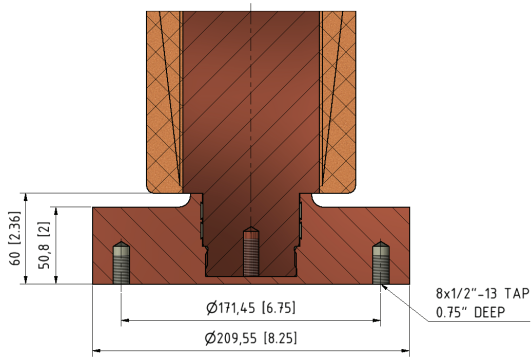

Bottom terminal 3(f)

+ optional flat pad terminal and electrode shield

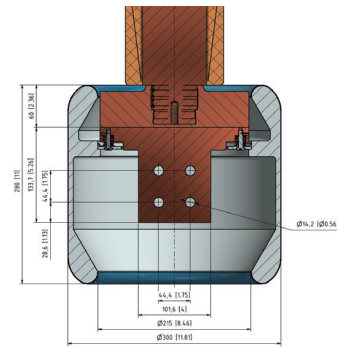

Minimum distance to earthed parts

The distance to the grounded parts is depending of voltage, transformer tank design as well as oil condition and quality.

R7 distance is given in the dimensions table.

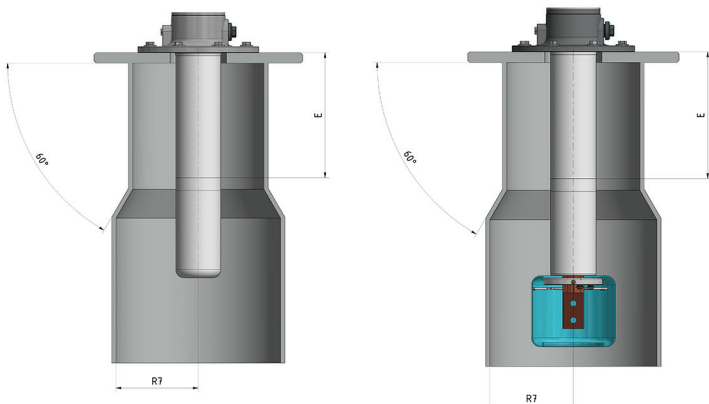

Um (kV)	R7 mm (in)
25	100
	3.94
46	100
	3.94
69	130
	5.12
115	160
	6.30
138	190
	7.48
161	230
	9.05
230	275
	10.83
345	370
	14.57

Accessories

Flat pad terminal

They are usually cast from aluminium but are also made on customer request from other materials (copper, brass).

More details on request.

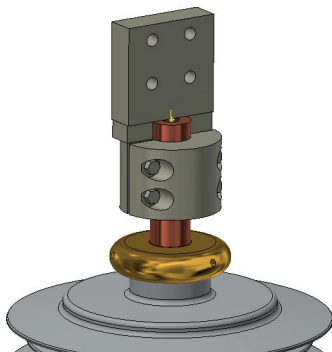

Shock indicator

On request, a shock indicator label can be fixed on the crate to check if it has experienced a mechanical shock.



Long term storage RIP bushings

Protective tank is used to protect parts of RIP bushing which are used under service in transformer oil against damages or humidity.

They are used for long term storage as well as for protection during long transports.

The protection tank is delivered mounted on the bushing and filled with dry insulating oil.

After the sealing an air cushion remains in the protection tank which is necessary for compensation purposes due to temperature-sensitive volume variations.

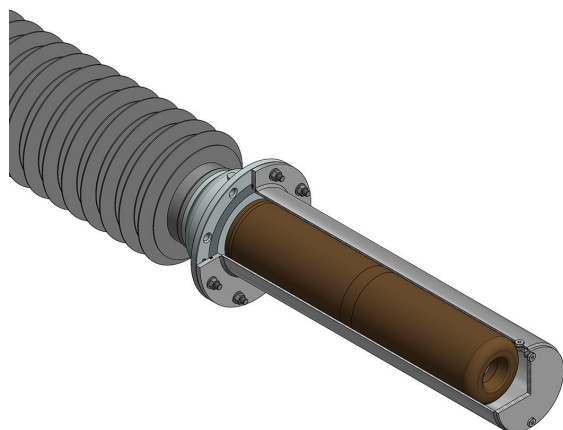

Offshore application (C5-M)

Moser Glaser has made investigations and performed tests according ISO 12944 and ISO 20340 to find the most efficient combination of products for heavy corrosive environment.

If you ordered a bushing for offshore application, the flange and the head of the bushing will be anodized, and the top terminal will be tin-plated.

Additional mounting advices are given in our online instruction manual www.mgc.ch.



Part numbering

BIL	Nominal system voltage	Line to ground voltage	Conductor type	Rated continuous current	CT extension	Top terminal	Lead connection method	RIP		RIS	
								Style number	Part number	Style number	Part number
kV	kV	kV		A	"						
150	25	16	Draw-lead	800	21	1.5"-UNF-2A	Brazing-pilot hole	P150-25-D08-21-T1-B1	600.17.0004.B01	S150-25-D08-21-T1-B1	605.17.0005.B01
150	25	16	Draw-lead	400	21	1.5"-UNF-2A	Crimping-0.433"	P150-25-D04-21-T1-C1	600.17.0004.B21	S150-25-D04-21-T1-C1	605.17.0005.B21
150	25	16	Draw-lead	400	21	1.5"-UNF-2A	Crimping-0.510"	P150-25-D04-21-T1-C2	600.17.0004.B22	S150-25-D04-21-T1-C2	605.17.0005.B22
150	25	16	Draw-lead	400	21	1.5"-UNF-2A	Crimping-0.590"	P150-25-D04-21-T1-C3	600.17.0004.B23	S150-25-D04-21-T1-C3	605.17.0005.B23
150	25	16	Draw-lead	400	21	1.5"-UNF-2A	Crimping-0.750"	P150-25-D04-21-T1-C4	600.17.0004.B24	S150-25-D04-21-T1-C4	605.17.0005.B24
150	25	16	Draw-lead	400	21	1.5"-UNF-2A	Crimping-0.945"	P150-25-D04-21-T1-C5	600.17.0004.B25	S150-25-D04-21-T1-C5	605.17.0005.B25
150	25	16	Draw-lead	400	21	1.5"-UNF-2A	Brazing-spade	P150-25-D04-21-T1-S	600.17.0004.B31	S150-25-D04-21-T1-S	605.17.0005.B31
150	25	16	Draw-rod	1200	21	1.5"-UNF-2A	1.5"-UNF-2A	P150-25-R12-21-T1-BT1	600.17.0004.B11	S150-25-R12-21-T1-BT1	605.17.0005.B11
150	25	16	Fix-conductor	2000	21	2.0"-UN-2A	2 holes spade	P150-25-F20-21-T2-24	600.17.0005.B01	S150-25-F20-21-T2-24	605.17.0008.B01
150	25	16	Fix-conductor	3000	21	3.0"-UN-2A	2 holes spade	P150-25-F30-21-T3-24	600.17.0006.B01	S150-25-F30-21-T3-24	605.17.0011.B01
200	34.5	22	Draw-lead	800	21	1.5"-UNF-2A	Brazing-pilot hole	P200-34.5-D08-21-T1-B1	600.17.0007.B01	S200-34.5-D08-21-T1-B1	605.17.0001.B01
200	34.5	22	Draw-lead	400	21	1.5"-UNF-2A	Crimping-0.433"	P200-34.5-D04-21-T1-C1	600.17.0007.B21	S200-34.5-D04-21-T1-C1	605.17.0001.B21
200	34.5	22	Draw-lead	400	21	1.5"-UNF-2A	Crimping-0.510"	P200-34.5-D04-21-T1-C2	600.17.0007.B22	S200-34.5-D04-21-T1-C2	605.17.0001.B22
200	34.5	22	Draw-lead	400	21	1.5"-UNF-2A	Crimping-0.590"	P200-34.5-D04-21-T1-C3	600.17.0007.B23	S200-34.5-D04-21-T1-C3	605.17.0001.B23
200	34.5	22	Draw-lead	400	21	1.5"-UNF-2A	Crimping-0.750"	P200-34.5-D04-21-T1-C4	600.17.0007.B24	S200-34.5-D04-21-T1-C4	605.17.0001.B24
200	34.5	22	Draw-lead	400	21	1.5"-UNF-2A	Crimping-0.945"	P200-34.5-D04-21-T1-C5	600.17.0007.B25	S200-34.5-D04-21-T1-C5	605.17.0001.B25
200	34.5	22	Draw-lead	400	21	1.5"-UNF-2A	Brazing-spade	P200-34.5-D04-21-T1-S	600.17.0007.B31	S200-34.5-D04-21-T1-S	605.17.0001.B31
200	34.5	22	Draw-rod	1200	21	1.5"-UNF-2A	1.5"-UNF-2A	P200-34.5-R12-21-T1-BT1	600.17.0007.B11	S200-34.5-R12-21-T1-BT1	605.17.0001.B11
200	34.5	22	Fix-conductor	2000	21	2.0"-UN-2A	2 holes spade	P200-34.5-F20-21-T2-24	600.17.0008.B01	S200-34.5-F20-21-T2-24	605.17.0012.B01
200	34.5	22	Fix-conductor	3000	21	3.0"-UN-2A	4 holes spade	P200-34.5-F30-21-T3-25	600.17.0009.B01	S200-34.5-F30-21-T3-25	605.17.0013.B01
250	46	29	Draw-lead	800	21	1.5"-UNF-2A	Brazing-pilot hole	P250-46-D08-21-T1-B1	600.17.0010.B01	S250-46-D08-21-T1-B1	605.17.0014.B01
250	46	29	Draw-lead	400	21	1.5"-UNF-2A	Crimping-0.433"	P250-46-D04-21-T1-C1	600.17.0010.B21	S250-46-D04-21-T1-C1	605.17.0014.B21
250	46	29	Draw-lead	400	21	1.5"-UNF-2A	Crimping-0.510"	P250-46-D04-21-T1-C2	600.17.0010.B22	S250-46-D04-21-T1-C2	605.17.0014.B22
250	46	29	Draw-lead	400	21	1.5"-UNF-2A	Crimping-0.590"	P250-46-D04-21-T1-C3	600.17.0010.B23	S250-46-D04-21-T1-C3	605.17.0014.B23
250	46	29	Draw-lead	400	21	1.5"-UNF-2A	Crimping-0.750"	P250-46-D04-21-T1-C4	600.17.0010.B24	S250-46-D04-21-T1-C4	605.17.0014.B24
250	46	29	Draw-lead	400	21	1.5"-UNF-2A	Crimping-0.945"	P250-46-D04-21-T1-C5	600.17.0010.B25	S250-46-D04-21-T1-C5	605.17.0014.B25
250	46	29	Draw-lead	400	21	1.5"-UNF-2A	Brazing-spade	P250-46-D04-21-T1-S	600.17.0010.B31	S250-46-D04-21-T1-S	605.17.0014.B31
250	46	29	Draw-rod	1200	21	1.5"-UNF-2A	1.5"-UNF-2A	P250-46-R12-21-T1-BT1	600.17.0010.B11	S250-46-R12-21-T1-BT1	605.17.0014.B11
350	69	160	Draw-lead	800	21	1.5"-UNF-2A	Brazing-pilot hole	P350-69-D08-21-T1-B1	600.17.0013.B01	S350-69-D08-21-T1-B1	605.17.0002.B01
350	69	160	Draw-lead	400	21	1.5"-UNF-2A	Crimping-0.433"	P350-69-D04-21-T1-C1	600.17.0013.B21	S350-69-D04-21-T1-C1	605.17.0002.B21
350	69	160	Draw-lead	400	21	1.5"-UNF-2A	Crimping-0.510"	P350-69-D04-21-T1-C2	600.17.0013.B22	S350-69-D04-21-T1-C2	605.17.0002.B22
350	69	160	Draw-lead	400	21	1.5"-UNF-2A	Crimping-0.590"	P350-69-D04-21-T1-C3	600.17.0013.B23	S350-69-D04-21-T1-C3	605.17.0002.B23
350	69	160	Draw-lead	400	21	1.5"-UNF-2A	Crimping-0.750"	P350-69-D04-21-T1-C4	600.17.0013.B24	S350-69-D04-21-T1-C4	605.17.0002.B24
350	69	160	Draw-lead	400	21	1.5"-UNF-2A	Crimping-0.945"	P350-69-D04-21-T1-C5	600.17.0013.B25	S350-69-D04-21-T1-C5	605.17.0002.B25
350	69	160	Draw-lead	400	21	1.5"-UNF-2A	Brazing-spade	P350-69-D04-21-T1-S	600.17.0013.B31	S350-69-D04-21-T1-S	605.17.0002.B31
350	69	160	Draw-rod	1200	21	1.5"-UNF-2A	1.5"-UNF-2A	P350-69-R12-21-T1-BT1	600.17.0013.B11	S350-69-R12-21-T1-BT1	605.17.0002.B11
350	69	160	Fix-conductor	2000	21	2.0"-UN-2A	2 holes spade	P350-69-F20-21-T2-24	600.17.0014.B01	S350-69-F20-21-T2-24	605.17.0017.B01
350	69	160	Fix-conductor	3000	21	3.0"-UN-2A	4 holes spade	P350-69-F30-21-T3-25	600.17.0015.B01	S350-69-F30-21-T3-25	605.17.0018.B01

Part numbering

BIL	Nominal system voltage	Line to ground voltage	Conductor type	Rated continuous current	CT extension	Top terminal	Lead connection method	RIP		RIS	
	kV	kV		A				"	Style number	Part number	Style number
550	115	88	Draw-lead	800	23	1.5"-UNF-2A	Brazing-pilot hole	P550-115-D08-23-T1-B1	600.17.0016.B01	S550-115-D08-23-T1-B1	605.17.0003.B01
550	115	88	Draw-lead	400	23	1.5"-UNF-2A	Crimping-0.433"	P550-115-D04-23-T1-C1	600.17.0016.B21	S550-115-D04-23-T1-C1	605.17.0003.B21
550	115	88	Draw-lead	400	23	1.5"-UNF-2A	Crimping-0.510"	P550-115-D04-23-T1-C2	600.17.0016.B22	S550-115-D04-23-T1-C2	605.17.0003.B22
550	115	88	Draw-lead	400	23	1.5"-UNF-2A	Crimping-0.590"	P550-115-D04-23-T1-C3	600.17.0016.B23	S550-115-D04-23-T1-C3	605.17.0003.B23
550	115	88	Draw-lead	400	23	1.5"-UNF-2A	Crimping-0.750"	P550-115-D04-23-T1-C4	600.17.0016.B24	S550-115-D04-23-T1-C4	605.17.0003.B24
550	115	88	Draw-lead	400	23	1.5"-UNF-2A	Crimping-0.945"	P550-115-D04-23-T1-C5	600.17.0016.B25	S550-115-D04-23-T1-C5	605.17.0003.B25
550	115	88	Draw-lead	800	23	1.5"-UNF-2A	Brazing-spade	P550-115-D08-23-T1-S	600.17.0016.B31	S550-115-D08-23-T1-S	605.17.0003.B31
550	115	88	For 1200A Bottom Connected please enquire Moser Glaser: info@mgc.ch								
550	115	88	Fix-conductor	2000	23	2.0"-UN-2A	Bottom terminal 3(e)	P550-115-F20-23-T2-35	600.17.0017.B01	S550-115-F20-23-T2-35	605.17.0019.B01
550	115	88	Fix-conductor	3000	23	3.0"-UN-2A	Bottom terminal 3(e)	P550-115-F30-23-T3-35	600.17.0018.B01	S550-115-F30-23-T3-35	605.17.0020.B01
650	138	102	Draw-lead	800	23	1.5"-UNF-2A	Brazing-pilot hole	P650-138-D08-23-T1-B1	600.17.0019.B01	S650-138-D08-23-T1-B1	605.17.0004.B01
650	138	102	Draw-lead	400	23	1.5"-UNF-2A	Crimping-0.433"	P650-138-D04-23-T1-C1	600.17.0019.B21	S650-138-D04-23-T1-C1	605.17.0004.B21
650	138	102	Draw-lead	400	23	1.5"-UNF-2A	Crimping-0.510"	P650-138-D04-23-T1-C2	600.17.0019.B22	S650-138-D04-23-T1-C2	605.17.0004.B22
650	138	102	Draw-lead	400	23	1.5"-UNF-2A	Crimping-0.590"	P650-138-D04-23-T1-C3	600.17.0019.B23	S650-138-D04-23-T1-C3	605.17.0004.B23
650	138	102	Draw-lead	400	23	1.5"-UNF-2A	Crimping-0.750"	P650-138-D04-23-T1-C4	600.17.0019.B24	S650-138-D04-23-T1-C4	605.17.0004.B24
650	138	102	Draw-lead	400	23	1.5"-UNF-2A	Crimping-0.945"	P650-138-D04-23-T1-C5	600.17.0019.B25	S650-138-D04-23-T1-C5	605.17.0004.B25
650	138	102	Draw-lead	800	23	1.5"-UNF-2A	Brazing-spade	P650-138-D08-23-T1-S	600.17.0019.B31	S650-138-D08-23-T1-S	605.17.0004.B31
650	138	102	For 1200A Bottom Connected please enquire Moser Glaser: info@mgc.ch								
650	138	102	Fix-conductor	2000	23	2.0"-UN-2A	Bottom terminal 3(e)	P650-138-F20-23-T2-35	600.17.0020.B01	S650-138-F20-23-T2-35	605.17.0021.B01
650	138	102	Fix-conductor	3000	23	3.0"-UN-2A	Bottom terminal 3(e)	P650-138-F30-23-T3-35	600.17.0021.B01	S650-138-F30-23-T3-35	605.17.0022.B01
750	161	102	Draw-lead	800	23	1.5"-UNF-2A	Brazing-pilot hole	P750-161-D08-23-T1-B1	600.17.0022.B01	S750-161-D08-23-T1-B1	605.17.0023.B01
750	161	102	Draw-lead	400	23	1.5"-UNF-2A	Crimping-0.433"	P750-161-D04-23-T1-C1	600.17.0022.B21	S750-161-D04-23-T1-C1	605.17.0023.B21
750	161	102	Draw-lead	400	23	1.5"-UNF-2A	Crimping-0.510"	P750-161-D04-23-T1-C2	600.17.0022.B22	S750-161-D04-23-T1-C2	605.17.0023.B22
750	161	102	Draw-lead	400	23	1.5"-UNF-2A	Crimping-0.590"	P750-161-D04-23-T1-C3	600.17.0022.B23	S750-161-D04-23-T1-C3	605.17.0023.B23
750	161	102	Draw-lead	400	23	1.5"-UNF-2A	Crimping-0.750"	P750-161-D04-23-T1-C4	600.17.0022.B24	S750-161-D04-23-T1-C4	605.17.0023.B24
750	161	102	Draw-lead	400	23	1.5"-UNF-2A	Crimping-0.945"	P750-161-D04-23-T1-C5	600.17.0022.B25	S750-161-D04-23-T1-C5	605.17.0023.B25
750	161	102	Draw-lead	800	23	1.5"-UNF-2A	Brazing-spade	P750-161-D08-23-T1-S	600.17.0022.B31	S750-161-D08-23-T1-S	605.17.0023.B31
750	161	102	Draw-rod	2000	23	2"-UNF-2A	Bottom terminal 3(e)	P750-161-F20-23-T2-34	600.17.0023.B01	S750-161-F20-23-T2-34	
900	230	146	Draw-lead	800	23	1.5"-UNF-2A	Brazing-pilot hole	P900-230-D08-23-T1-B1	600.17.0025.B01	S900-230-D08-23-T1-B1	605.17.0026.B01
900	230	146	Draw-lead	400	23	1.5"-UNF-2A	Crimping-0.433"	P900-230-D04-23-T1-C1	600.17.0025.B21	S900-230-D04-23-T1-C1	605.17.0026.B21
900	230	146	Draw-lead	400	23	1.5"-UNF-2A	Crimping-0.510"	P900-230-D04-23-T1-C2	600.17.0025.B22	S900-230-D04-23-T1-C2	605.17.0026.B22
900	230	146	Draw-lead	400	23	1.5"-UNF-2A	Crimping-0.590"	P900-230-D04-23-T1-C3	600.17.0025.B23	S900-230-D04-23-T1-C3	605.17.0026.B23
900	230	146	Draw-lead	400	23	1.5"-UNF-2A	Crimping-0.750"	P900-230-D04-23-T1-C4	600.17.0025.B24	S900-230-D04-23-T1-C4	605.17.0026.B24
900	230	146	Draw-lead	400	23	1.5"-UNF-2A	Crimping-0.945"	P900-230-D04-23-T1-C5	600.17.0025.B25	S900-230-D04-23-T1-C5	605.17.0026.B25
900	230	146	Draw-lead	800	23	1.5"-UNF-2A	Brazing-spade	P900-230-D08-23-T1-S	600.17.0025.B31	S900-230-D08-23-T1-S	605.17.0026.B31
900	230	146	Fix-conductor	2000	23	2.0"-UN-2A	Bottom terminal 3(e)	P900-230-F20-23-T2-35	600.17.0026.B01	S900-230-F20-23-T2-35	605.17.0027.B01
900	230	146	Fix-conductor	3000	23	3.0"-UN-2A	Bottom terminal 3(e)	P900-230-F30-23-T2-35	600.17.0027.B01	S900-230-F30-23-T2-35	605.17.0028.B01
1175	345	220	Draw-lead	800	23	1.5"-UNF-2A	Brazing-pilot hole	P1175-345-D08-23-T1-B1	600.20.0006.B01	S1175-345-D08-23-T1-B1	605.20.0002.B01
1175	345	220	Draw-lead	2000	23	2.0"-UN-2A	Bottom terminal 3(f)	P1175-345-F20-23-T2-36	600.17.0032.B01	P1175-345-F20-23-T2-36	605.20.0003.B01

Production facility

Winding



Impregnation



Machining



Production facility

Silicone insulator molding

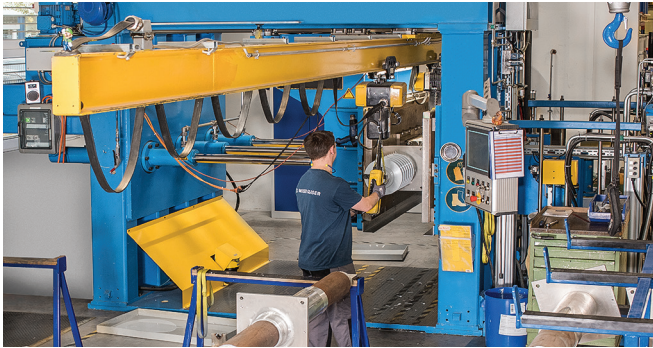

Routine / type tests



Packaging



DURESCA®
Busbar system

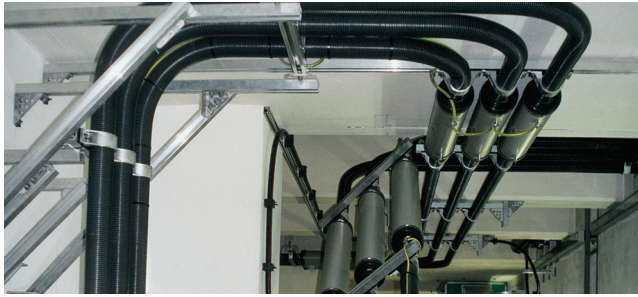

TIRESCA®
Busbar system



GASLINK®
SF₆ insulated busbar system



DURESCA®
Wall bushings



DURESCA®
Transformer bushings



 **MOSER GLASER**
Current and voltage – our passion

MGC Moser-Glaser Ltd.
Lerchenweg 21
4303 Kaiseraugst
Switzerland

 +41 61 467 61 11
 info@mgc.ch
 www.mgc.ch

Member of PFIFFNER Group

This document has been drawn up with the utmost care. We can not however, guarantee that it is entirely complete, correct or up-to-date.
© Copyright Moser Glaser, Subject to change without notice. 2021.08

Represented by: