

RSG482

Recurrent Surge Generator

Datasheet



HAEFELY

Current and voltage – our passion

General Description

Recurrent Surge Generator 482 is a bench-top, one stage, low voltage equivalent of a high voltage impulse generator. Its wide range of applications includes the testing of models, the study of voltage distribution in high voltage windings during impulse voltage stresses and the predetermination of the circuit parameters of impulse test plants.

Tests can be performed quickly and reliably without endangering personnel. All impulse circuit elements and, therefore, all impulse wave forms may be varied within broad limits with selector knobs. Due to the repetition frequency of 25 Hz, the voltage impulse may be observed and evaluated on any oscilloscope as a standing image.

All impulse circuit components may be adjusted in steps.

The impulse shape can thus be fine-tuned within a wide range. Additional capacitors and resistors can be

connected externally to permit operation with larger impulse capacitances and other resistance values.

The peak value of the impulse voltage is stabilized and continuously adjustable. The voltage impulse may be chopped internally within broad limits.

The unit also features a continuously adjustable oscilloscope trigger delay which may be set from trigger delay through zero to pre trigger.

The RSG 482 is a bench-top model which can also be mounted into 19" racks. All input and output jacks are located at the rear panel of the unit. All controls are arranged on the front panel for easy access.

Features

- All Impulse parameters can be adjusted in steps through rotary switches
- Additional capacitors and resistors can be connected externally
- Output voltage continuously adjustable and stabilized
- Continuously adjustable oscilloscope trigger delay

Applications

- Investigating the impulse voltage distribution in winding models of machines, transformers, reactors and instrument transformers
- Predetermining impulse circuit data, for instance the value of the front resistance of an impulse generator, which can be performed by connecting the actual test object
- Non-destructive testing of windings in dry state and under various impulse voltage conditions
- Insulation fault localisation in windings
- Investigating transfer characteristics of measuring systems
- Transient wave measurement in cables and models
- Training and experimentation in laboratories of technical colleges and electro technical institutes

Basic Diagram

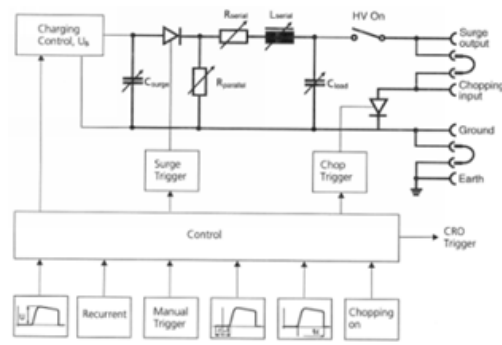

Operation



- 1 Output voltage adjustment
- 2 CRO trigger adjustment
- 3 Chopping time adjustment
- 4 R_p (tail resistor) selector knob
- 5 R_s (front resistor) selector knob
- 6 L (series inductance) selector knob
- 7 C_L (load capacitance) selector knob
- 8 C_s (imp. capacitance) selector knob
- 9 Chopping ON/OFF
- 10 Recurrent triggering
- 11 Manual triggering
- 12 Mains switch

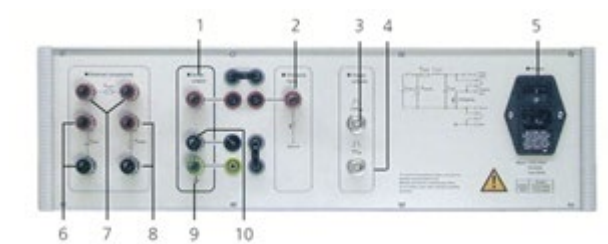

- 1 Impulse voltage output
- 2 Chopping circuit input
- 3 Oscilloscope triggering +180 V
- 4 Oscilloscope triggering +7.5 V
- 5 Mains input
- 6 C_s external impulse capacitance
- 7 R_s external front resistor
- 8 R_p external tail resistor
- 9 Grounding terminal
- 10 Common

The principle of operation of the recurrent surge generator is shown in Figure 5. The voltage is stabilised via the charging control circuit. The firing and chopping times are adjusted with the two thyristors „surge" and „chop" in the timing control circuit.

The entire event can be recorded with an oscilloscope as a stationary image and moved along the time base with the aid of the adjustable CRO trigger signal. This CRO trigger signal is available at BNC jacks with two different voltage levels. By rotating the impulse circuit component selector switches Cs, Rs, L, Rp, CL, the operator can vary the impulse shape.

The impulse circuit is floating. A plug can be inserted in the rear panel to connect the common output to ground. The impulse generation sequence is repeated and synchronised with the mains frequency when the „push for recurrent" key is depressed.

The impulse can also be triggered manually in a non-recurrent manner by pressing the „manual trigger" key. The chopping circuit is activated by pressing the „chopping on" key. The „chop" thyristor circuit may be disconnected from the impulse circuit by removing a bridge between the sockets [Rear 1 and 2] located at the rear panel. The Cs, Rp, and Rs selector switches are provided with an „External" position. In this position, additional impulse circuit elements can be connected to the respective universal terminals located at the rear panel.

Combined tests with AC or DC voltages up to 90 V between Ground [Rear 9] and Common [Rear 10] (housing) are possible due to the floating output.

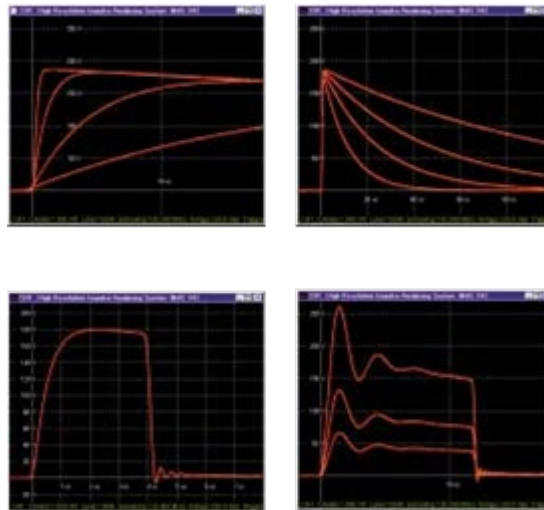

1. Front time selection by Rs adjustment
2. Time to half-value selection by Rp adjustment
3. Lightning impulse 1.2/50 μ s chopped after approx. 4 μ s
4. Chopped impulse at various charging voltages U Overshoot simulated via selection of series inductance L

Technical Data

General	
Charging Voltage	0...500 V \pm 2%
Chopping delay	continuously 0.3 – 6.0 μ s
Chopping decay	approximately 100 ns
CRO Trigger delay	-5 μ s...+30 μ s
Impulse Capacitance Selector, Cs	4.7 nF, 6.8 nF, 10 nF, 22 nF, 33 nF, 47 nF, 68 nF, 100 nF, 220 nF, 330 nF, 470 nF, 680 nF, 1000 nF, „Ext.“
Impulse Shape (front time), minimum	0.2 μ s
Impulse Shape (time to half value)	internal Cs: 0.3...3500 μ s external Cs: 0.3...9000 μ s
Inductance Selector, L	0 μ H, 10 μ H; 20 μ H; 30 μ H; 40 μ H; 50 μ H; 60 μ H; 70 μ H; 80 μ H; 90 μ H; 100 μ H.
Load Capacitance Selector, CL	nF, 0.47 nF, 0.68 nF, 1 nF, 2.2 nF, 3.3 nF, 4.7 nF, 6.8 nF, 10 nF, 22 nF, 33 nF, 47 nF, 68 nF, 100 nF
Parallel Resistor Selector, Rp	10 Ω , 15 Ω , 22 Ω , 33 Ω , 47 Ω , 68 Ω , 100 Ω , 150 Ω , 220 Ω , 330 Ω , 470 Ω , 680 Ω , 1.0 k Ω , 1.5 k Ω , 2.2 k Ω , 3.3 k Ω , 4.7 k Ω , 6.8 k Ω , 10 k Ω , 15 k Ω , „Ext.“
Rated Voltage Cs EXT	0...500 V
Rated Voltage Rp EXT	0...500 V
Rated Voltage Rs EXT	0...500 V
Repetition Rate (using external Cs)	1.6 / 1.9 Hz (depends on power frequency 50/60 Hz)
Repetition Rate (using internal Cs)	25 / 30 Hz (depends on power frequency 50/60 Hz)
Series Resistor Selector Rs	3.3 Ω , 4.7 Ω , 6.8 Ω , 10 Ω , 15 Ω , 22 Ω , 33 Ω , 47 Ω , 68 Ω , 100 Ω , 150 Ω , 220 Ω , 330 Ω , 470 Ω , 680 Ω , 1.0 k Ω , 1.5 k Ω , 2.2 k Ω , 3.3 k Ω , 4.7 k Ω , „Ext.“
Trigger output:	180 Vpp 10 Vpp shape approximately 0.5 / 4 μ s

Environmental, Mechanical and Power Supply	
Operating temperature	0...45 $^{\circ}$ C
Storage temperature	(non condensing) 0...95%
Dimensions (W x D x H)	19", 3 units high: 50 cm, 15 cm, 40 cm
Weight	20 kg
Power supply Spec.	115 V / 230 V (50/60 Hz)

Global Presence

Europe

HAEFELY AG
Birsstrasse 300
4052 Basel
Switzerland

☎ + 41 61 373 4111
✉ sales@haefely.com

China

HAEFELY AG Representative Office
8-1-602, Fortune Street, No. 67
Chaoyang Road, Beijing 100025
China

☎ + 86 10 8578 8099
✉ sales@haefely.com.cn

This document has been drawn up with the utmost care. We cannot, however, guarantee that it is entirely complete, correct or up to date.
©Copyright HAEFELY/ Subject to change without notice

V20XX.XX



HAEFELY

Current and voltage – our passion



HIGH VOLTAGE



INSTRUMENTS



EMC

precision.
swiss made.