

**DURESCA®**

## Installation Instructions Wall Bushings



Homepage	Created	Released	Revision	Page
<a href="http://www.mgc.ch">www.mgc.ch</a>	GBI 11.06.2024	SMU 11.06.2024	A	1/20

	Topic	File name
Technical data	Wall and Roof bushings	WD2020-12-E

## Wall and roof bushing application



**MGC MOSER GLASER**  
Lerchenweg 21  
Kaiseraugst / Switzerland  
Phone.: +41 61 467 61 11  
[info@mgc.ch](mailto:info@mgc.ch) / [www.mgc.ch](http://www.mgc.ch)

### Table of Contents

1	General .....	3
1.1	Safety .....	3
1.2	Transport and Storage .....	4
2	Product description .....	6
3	Specifications .....	7
4	Installation of the bushings .....	8
4.1	Unpacking and lifting .....	8
4.2	Installation of the bushing on wall or roof .....	9
4.3	Accessories mounting .....	10
5	Check before energizing .....	13
6	Nameplate .....	18
7	Maintenance .....	19
7.1	Capacity and Tan Delta measurements (see chapter 5) .....	19
7.2	Cleaning the silicone sheds .....	19
7.3	Recycling the bushing .....	19

## 1 General

Read this manual carefully and follow all safety regulations at work.

### 1.1 Safety



Work on bushings may only be performed by qualified people.

Follow the safety instructions of the operating company.

For your safety, before any manipulation inform the responsible person about your action in the field.

Do not energize the bushing without a closed measuring tap.



#### **Caution - Do not work on systems that might be under tension!**

Follow below safety rules in the given order.

- 1 Verify that the system is off-line
- 2 Disconnect from the mains Secure against reconnection
- 3 Secure against reconnection
- 4 Carry out earthing and short circuiting
- 5 Provide protection from adjacent live parts

**Not following these rules could cause death!**



**Caution** Strong electromagnetic fields can occur along the bushings.  
People with pacemakers may not stand near!

Sensitive technical devices must be protected by appropriate measures.



Only materials provided by MGC must be used (terminals, arcing horns...).

## 1.2 Transport and Storage

The bushings are packed in wooden crates (Figure 1). The crate should be free off any damage after delivery.

- On request, a shock indicator label can be fixed on the crate in order to check if the crate experienced a mechanical shock.



### Transport damage

1. Visible damage must be reported on the counter signed delivery note at the reception of the goods.
2. Moser Glaser shall be informed with no delay if a damage is reported.



### Bushings must always be protected from moisture.

Keep the protective foil until the installation.



### Storage

The bushing must always be protected from moisture and permanently stored in a dry room.

	Topic	File name
Technical data	Wall and Roof bushings	WD2020-12-E



Figure 1: wooden crate



Figure 2: bushing with CT



Figure 3: protective foil or protective foam

	Topic	File name
Technical data	Wall and Roof bushings	WD2020-12-E

## 2 Product description

The DURESCA wall bushings are designed to conduct the electrical energy through a wall or a roof. If present, silicone rubber sheds are molded on the outdoor side of the bushing.

The DURESCA wall bushing conducts the electrical current by a round conductor in copper or aluminium. It is characterised by a compact design and is partial-discharge-free during service. The DURESCA wall bushing is maintenance-free.

The DURESCA wall bushing has a dry insulation of RIP (Resin Impregnated Paper). The insulation lies directly on the conductor and consists of wrapped paper impregnated with special epoxy resin under vacuum. Conductive grading layers are embedded during the wrapping of the paper for an optimal distribution of the electrical field. This structure ensures the longest operational reliability and the highest human safety.

A dry insulation of RIS (Resin Impregnated Synthetic) is also available.

### High-quality coating for type DM, DMI.

To protect the RIP body for indoor application, a high-quality coating is applied with a thickness of 30 – 40 µm. This coating is resistant to water, diluted acids and chemicals and has excellent resistance properties against abrasion.

### Silicone insulator for type DMI, DM2I.

The silicone rubber insulator with alternating sheds has a uniform creepage distance of min. 31 mm/kV SCD or 53.7mm/kV USCD. This corresponds to a class 4 according to IEC 60815-1 Ed 2008 for very high pollution level.

### Polyamide tube for type DEM (only for indoor application).

The polyamide tube provides barrier against humidity and moisture ingress and mechanical protection.

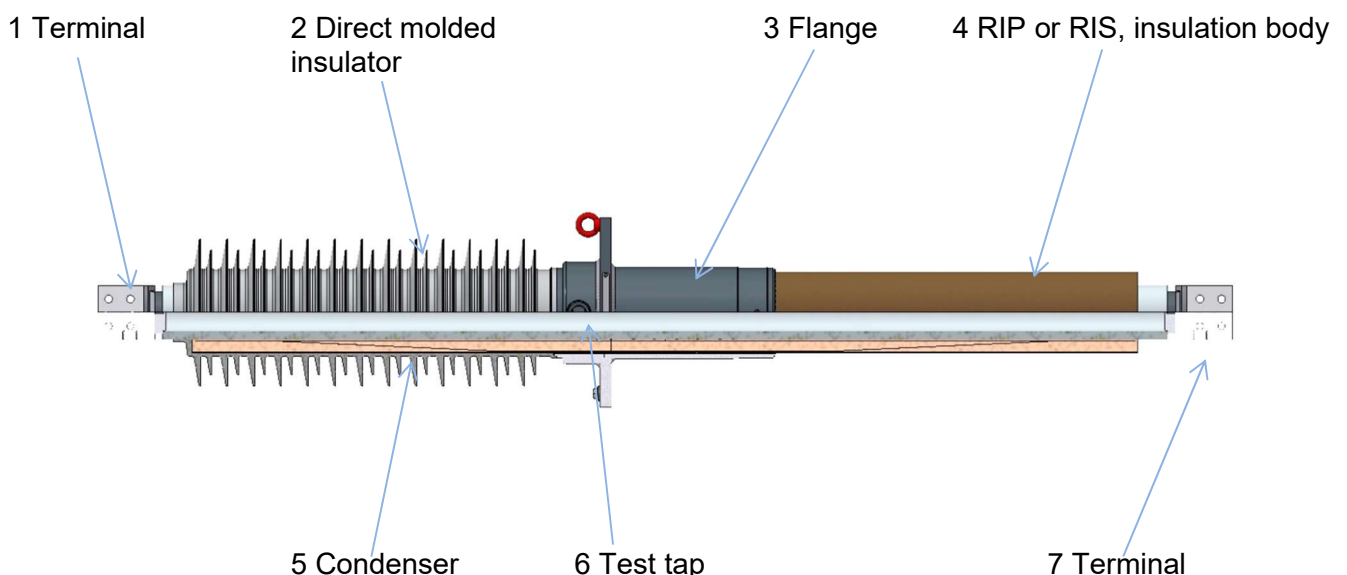

	Topic	File name
Technical data	Wall and Roof bushings	WD2020-12-E

### 3 Specifications

	Standard	Comments
<b>Electrically</b>		
Rated voltage $U_m$	-	see order confirmation
Max. current $I_r$ (with 1.2 overload)	-	see order confirmation
Standard	IEC 60137 / IEEE C57.19.00	see order confirmation
<b>Mechanically</b>		
Bushing type	Dry fine graded condenser type	
Material of conductor	Aluminium EN AW-6101B T7 (AC041) or Electrolyte copper (Cu-ETP)	see order confirmation
Insulation	RIP Resin Impregnated Paper RIS Resin Impregnated Synthetic	
Material flange	corrosion free aluminium alloy	
Material outdoor insulation	Silicone (LSR)	
Dimension	-	see layout drawing
Weight	-	see layout drawing
Wooden transport boxes	according ISPM 15 Standard (standard packaging, seaworth)	(ISPM: International Standards for Phytosanitary Measures)
<b>Application</b>		
Permissible ambient temperature	-40 up to +40° C	other values on request see layout drawing
Altitude	up to 1000 masl	other values on request
Application	Wall or roof bushing	outdoor of indoor
Mounting angle	0 to 90°	
Pollution degree	Min. 31mm/kV SCD Min. 53.7 mm/kV USCD	according IEC 60815

## 4 Installation of the bushing



Caution

Do not work on installations that might be under tension!

### 4.1 Unpacking and lifting



Attention

Bushings must be handled with care. Bumps and shocks should be avoided and reported.

Damage on the bushings must be reported immediately to Moser Glaser.

Attention

Do not use cutting tools to remove the protection foil as they might damage the silicone sheds.



Small bushing could be taken out of the crate by hand (for the weight, consult layout drawing).

For all other bushings, use slings, eyebolts and a crane like as on following view.

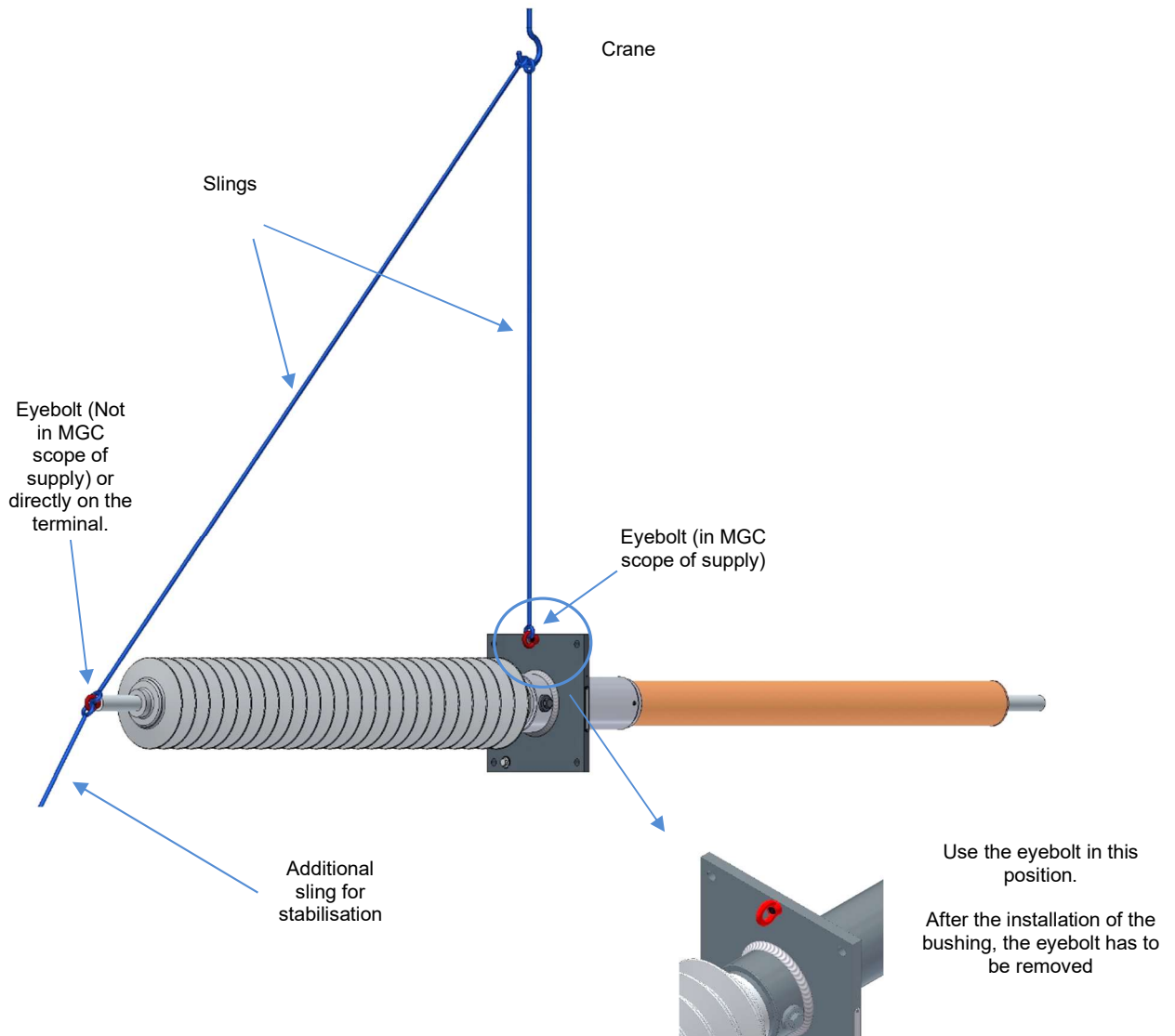

## 4.2 Installation of the bushing on wall or roof

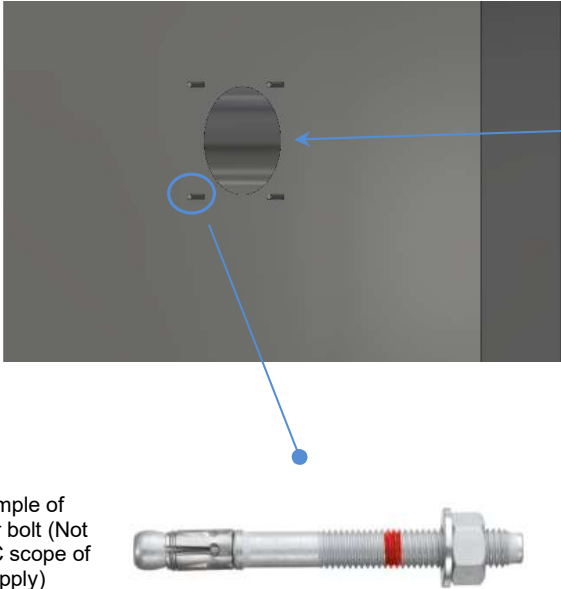
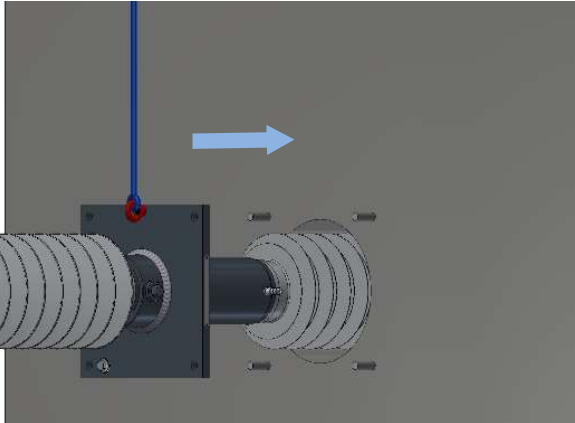
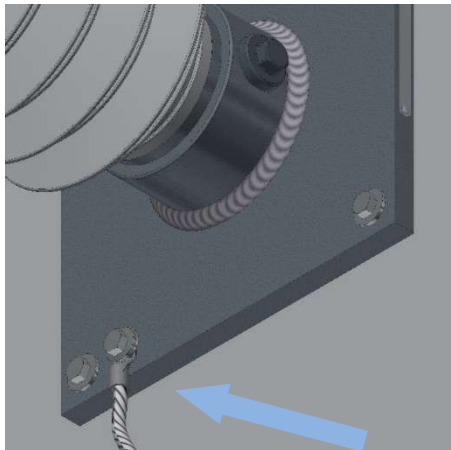
 <p>Example of Anchor bolt (Not in MGC scope of supply)</p>	<p><b>1</b></p> <p>Before installing the bushing on the wall or on the roof, control the diameter of the opening to avoid any damages on the bushing.</p> <p>Check the distance between the anchor bolts and compare it to the flange dimensions on the customer drawing.</p> <p>Make sure that the anchor bolts are suitable to carry the weight of the bushing.</p> <p>The installation company must also know the quality of the wall (concrete, brick, etc.)</p>
	<p><b>2</b></p> <p>Put the bushing through the wall or roof opening and tighten the nuts or bolts to the appropriate torque.</p>
	<p><b>3</b></p> <p>Make the earthing of the flange.</p> <p>Screw, spring washer and washer are in MGC scope of supply.</p> <p>Then, connect both bushing terminals.</p> <p>Torque M12 = 35 Nm</p>



**Attention**

MGC is not responsible for anchor bolts, torque moment, quality of wall, etc.  
For any questions, contact the installation company.

**4.3 Accessories mounting**

**Voltage divider**

Voltage divider is a linear circuit that produce an output voltage ( $V_{out}$ ) which is a fraction of the phase to earth voltage ( $V$ ).

Voltage ratio refers to the partitioning of a voltage among the components of the divider.

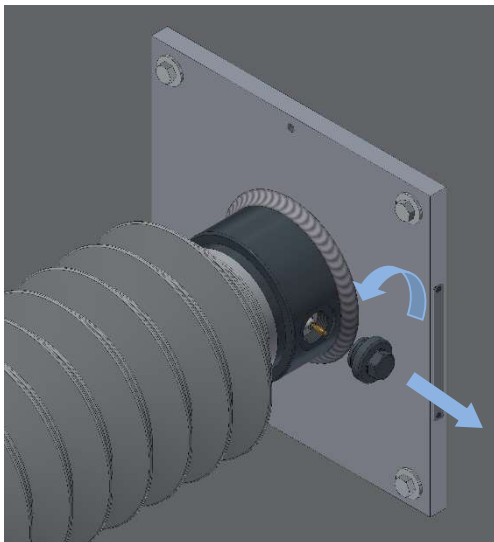

**1**

Unscrew the test tap cap.

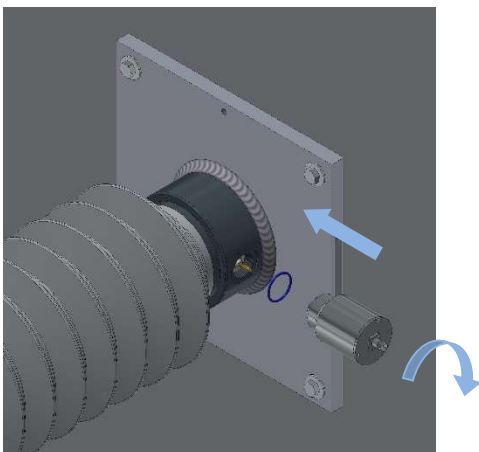

**2**

Put the O-ring in the groove located on the top of the voltage divider.  
Screw it on the flange in place of the test tap cap.

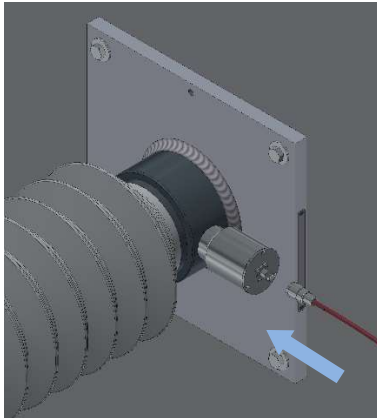

**3**

Connect the coaxial cable on the TNC connector.

Connect the other side of the cable on your monitoring device.

### Flat pad terminal

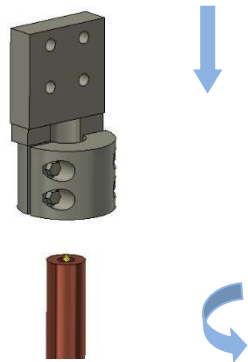

**1**

Put the flat pad terminal on the terminal.  
Adjust the orientation.

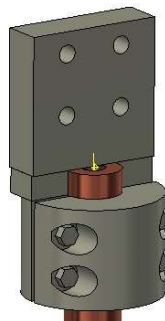

**2**

Tighten the bolts to the adequate torque moment in order to have a good electrical contact between the parts (see on the clamp).

 Current and voltage – our passion	Installation instructions <b>WALL BUSHINGS</b>	
	Topic Wall and Roof bushings	File name WD2020-12-E
Technical data	Wall and Roof bushings	

**Current transformer**



MGC wall bushings can be equipped with current transformers from our mother company **PIFFNER Instruments Transformers Ltd** Hirschthal, Switzerland.

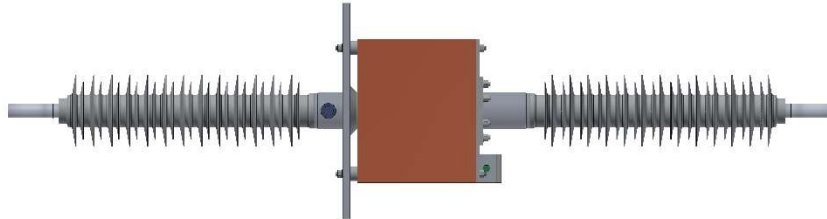

**Caution**

Do not work on systems that might be under tension!

Be aware of high voltage which might be generated in the secondary circuit due to electromagnetic fields coming from the bushing or nearby power unit.

The secondary connection must be carried out according to the scheme in the cable box.



Fig. 7: wall bushing with current transformer

Fig. 8: Example of cable box and nameplate for a current transformer with two cores

*Note: The current transformers accuracy depends on the dimensioning of the secondary line section.*



**Attention**

Each secondary circuit must be grounded at one point.

Do not energize wall bushings if a secondary circuit is still open!

Unused windings must be short circuited with the highest tap.

## 5 Check before energizing



### Check earthing

Inadequate earthing may lead to the failure of the installation and damage the bushings!



The test tap may only be used if the power supply is disconnected. After the measurements, the cap must be closed tight (30Nm).

To ensure safe operation, Moser Glaser recommends the following checks:

1. Tan Delta and capacity at the test tap (if possible)

### Measurement of the $\tan \delta$ and capacitance

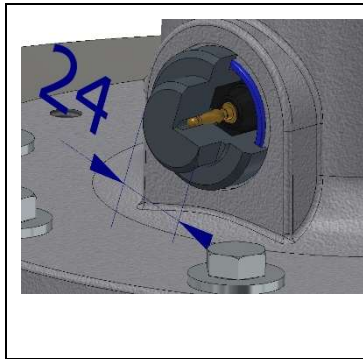

Use a flat spanner or spanner socket N24 to open the cap.

After the measurement, replace the cap and the O-ring. Torque 30Nm.

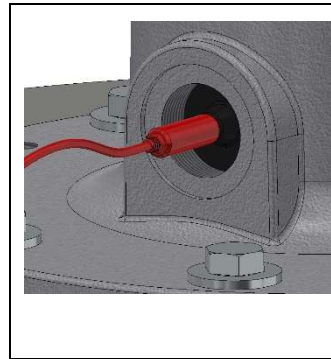

Connection:  
multilam pin  
 $\varnothing 4\text{mm}$

**use a banana  
jack to connect**

Measurement  
cable not  
included

In operation, grounded

Measurement position, not grounded

**Do not use the crocodile clip**

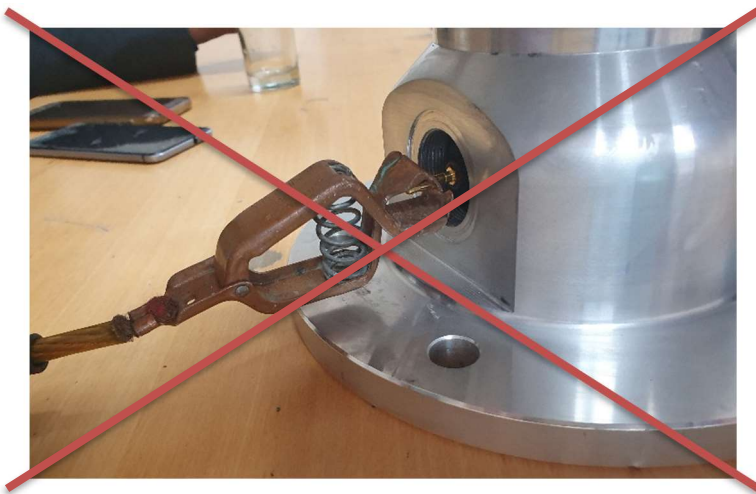

Dimension of the test tap

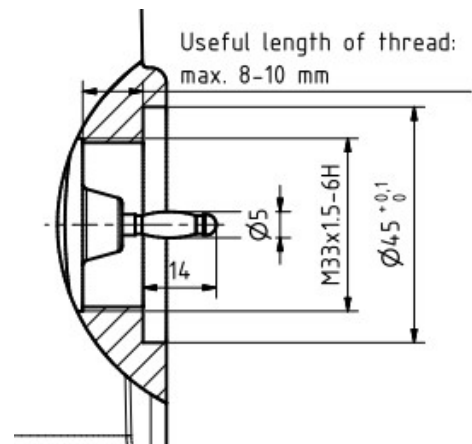

	Topic	File name
Technical data	Wall and Roof bushings	WD2020-12-E

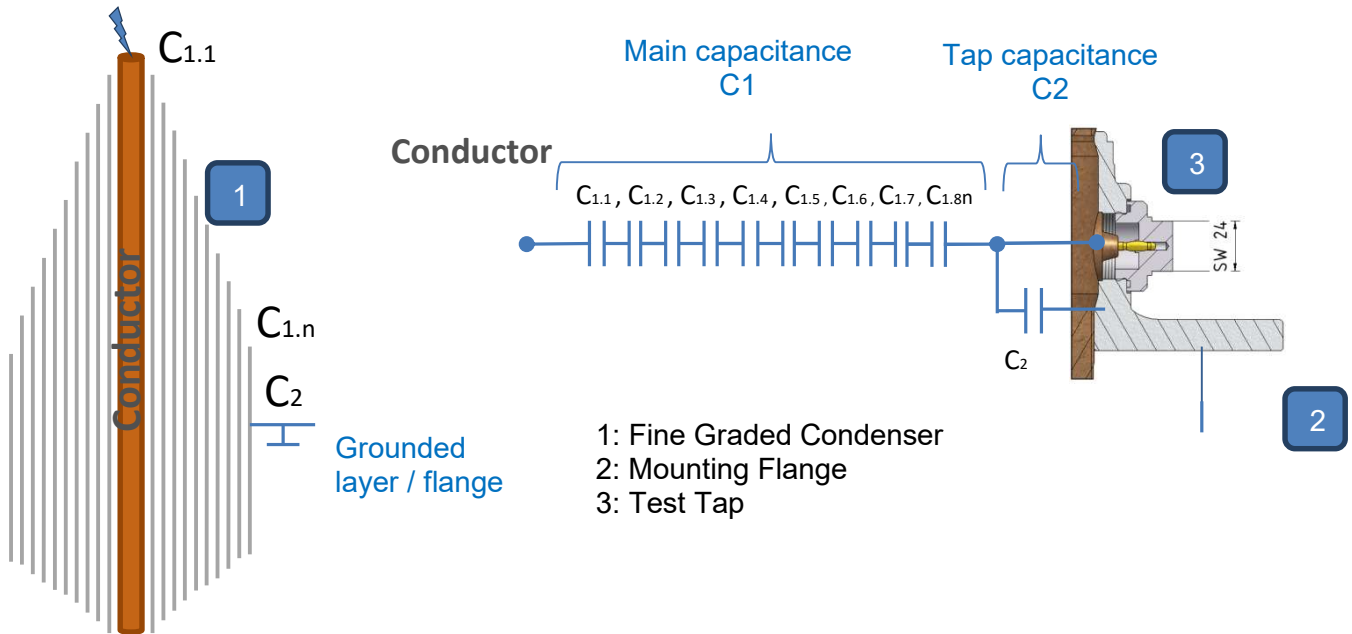

Figure 7: Principle of capacitance and Tan Delta measurement.

### Capacitances C1 and C2

The capacitance is defined by the geometry of the active part (position and length of the capacitive layers, size of the flange, ...).

Following parameters can influence the value of capacitance:

- Temperature: permittivity and then capacitance increase with increasing temperature
- Stray capacitances: presence of a current transformer, a turret, connections, distance to ground...

Values can therefore deviate from manufacture values:

- For main insulation C1: up to 10%
- For test tap C2: up to 100%

### Power factor / $\tan \delta_1$ (Main insulation) and $\tan \delta_2$ (Test tap)

The ideal bushing is a pure capacitance, but the real bushing is an ideal capacitance associated with a resistance. The loss factor is defined by the ratio between resistive and capacitive currents of the tested part:

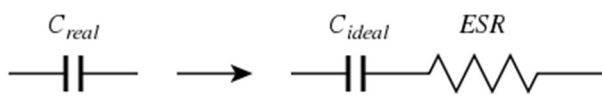

ESR: Equivalent Series Resistance

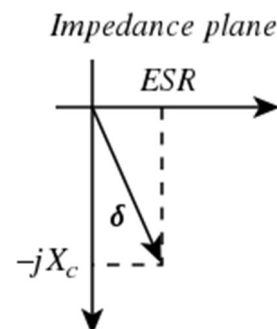

	Topic	File name
Technical data	Wall and Roof bushings	WD2020-12-E

### How to limit $\tan \delta_1$

- Avoid moisture and dust to penetrate inside of the test tap (always close test tap with the original cap when not used)
- Limit the exposition of the bushing to moisture (indoor storage, sealed packaging, ...)
- Measure in the best conditions:
  - Outside of the wooden crate
  - Flange earthed but insulated from any other material (polystyrene, wood, ...)

### Importance of $\tan \delta_2$

- **In operation, the last layer is earthed, so that C2 is shortened:**
  - **No dielectric losses**
  - **No dielectric stress**
  - **No partial discharge activity**
- **It is not recommended to use  $\tan \delta_2$  for bushing diagnostic as this parameter is highly volatile especially with temperatures changes.**

### Following parameters can influence the value of $\tan \delta$ :

- Moisture: humidity content decreases the resistance and therefore increase the  $\tan \delta$
- Surface cleanness: any conductive part at the surface may lead to an increase of  $\tan \delta$ .  
By example: dusty silicone sheds, dusty or wet creepage distance (measurement in wooden crate)
- Temperature:  
With increasing temperature:
  - $\tan \delta_1$  decreases (in temperature range 10...60°C)
  - $\tan \delta_2$  increases

Values can therefore deviate from manufacture values:

- For main insulation  $\tan \delta_1$ : -0.5...-1.0 %/K in range 10...60°C
- For test tap  $\tan \delta_2$ : up to 100%

### Acceptance criteria:

- Capacity C1 :** Should not change more than 10% under the same test conditions as performed at Moser Glaser test lab.
- Tan  $\delta_1$  :** It should not exceed 0.7%, and should not change more than 0.10% between  $1.05U_m/\sqrt{3}$  and  $U_m$ . The results should be compared with nameplate values or (if available) the previous measurement performed in operation conditions.

The test results depend on the measurement method, temperature, air pressure and moisture. Make measurements at ambient temperature of 20°C for better comparability.

The following graph presents on-site acceptable values of loss factor  $\tan \delta$  and capacitance change at different bushing temperature for **RIP bushings**:

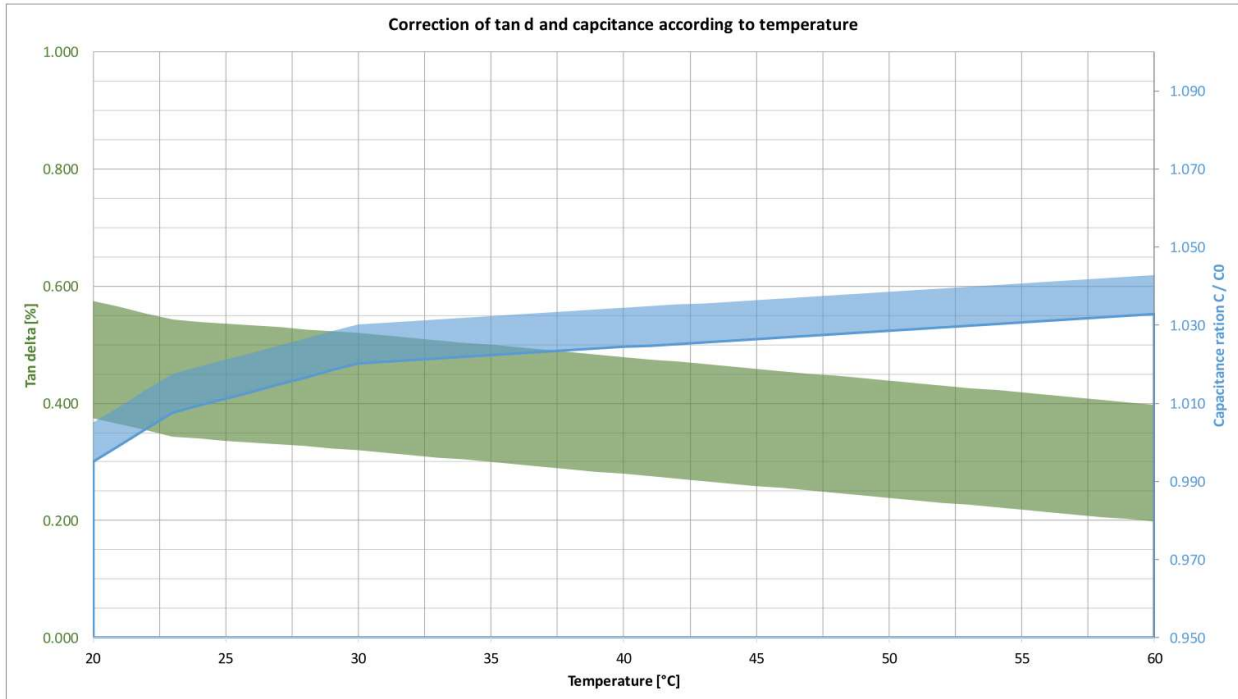

The curve below presents correction factor to calculate the loss factor  $\tan \delta$  at 20°C:

$$(T) = k_f \cdot \theta_{20^\circ c}$$

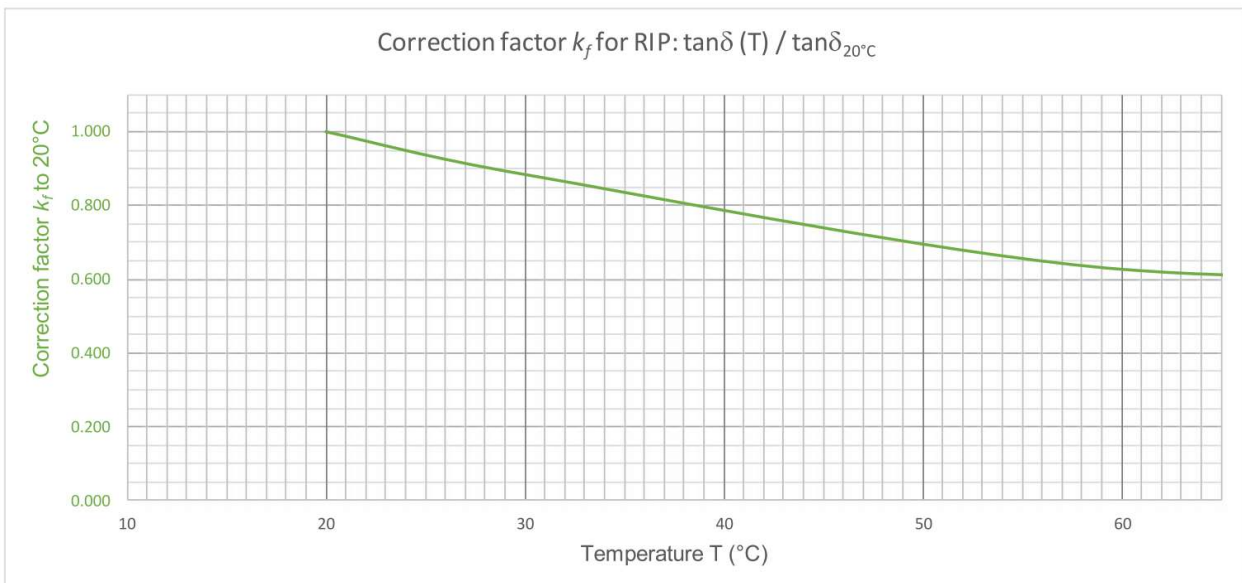

The following graph presents on-site acceptable values of loss factor  $\tan \delta$  and capacitance change at different bushing temperature for **RIS bushings**:

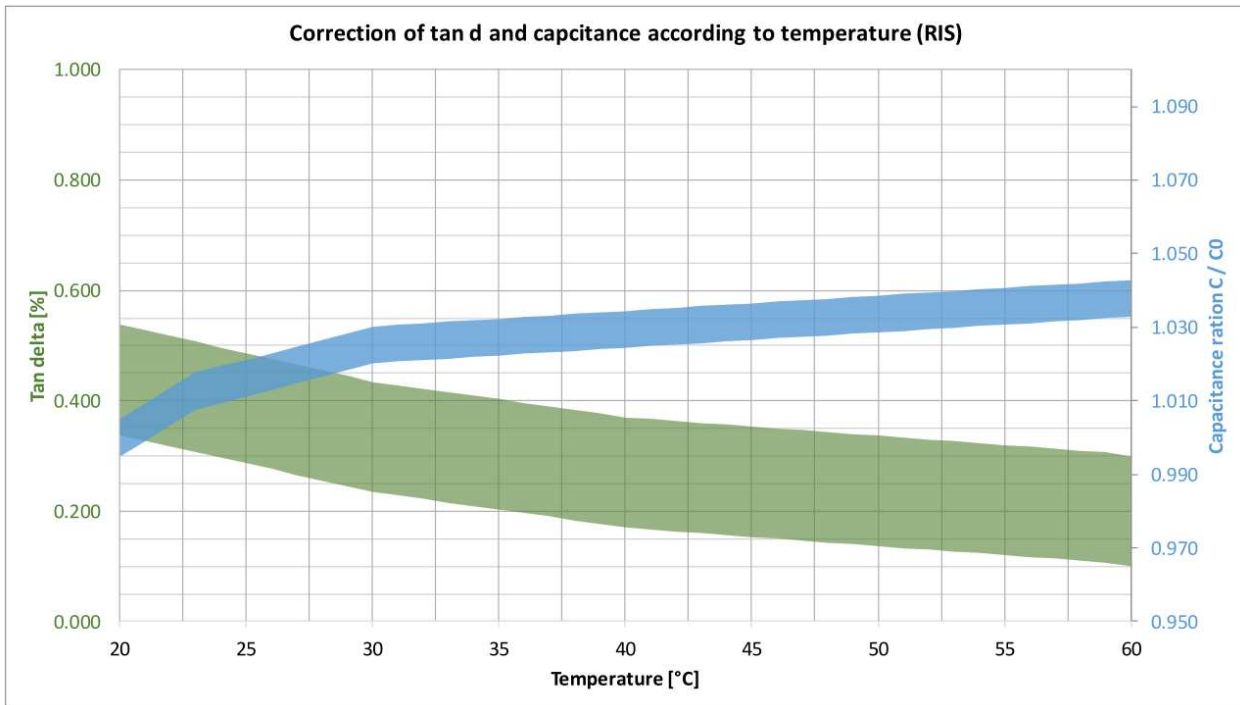

The curve below presents correction factor to calculate the loss factor  $\tan \delta$  at 20°C:

$$(T) = k_f \cdot \theta_{20^\circ C}$$

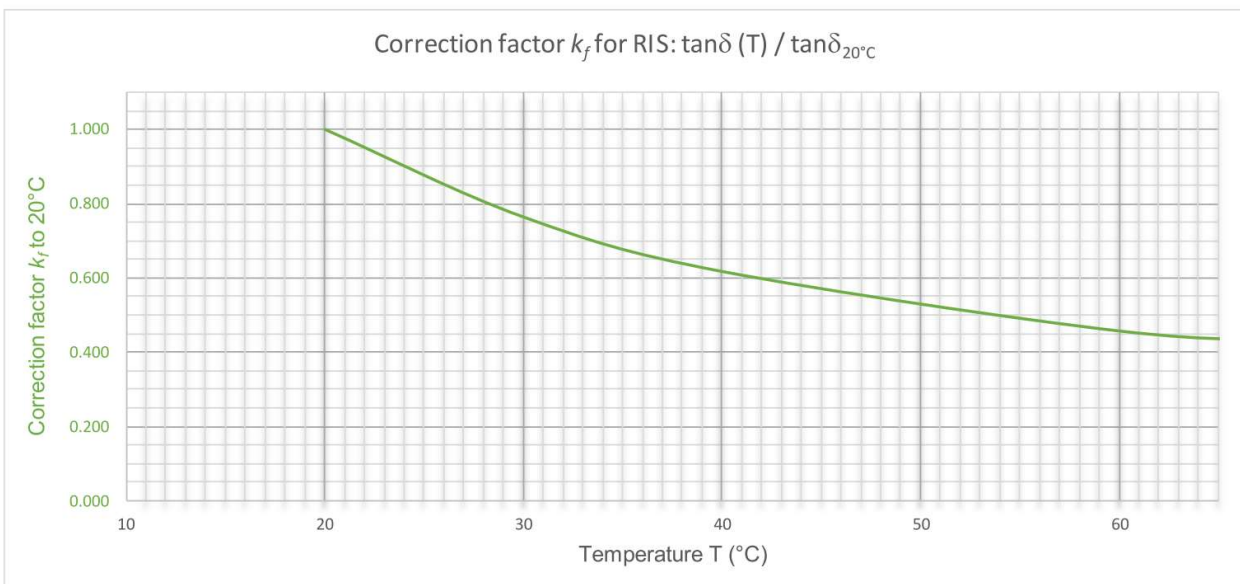

Contact Moser Glaser for the interpretation of results from measurement took in different conditions.

 Current and voltage – our passion	Installation instructions <b>WALL BUSHINGS</b>	
	<b>Topic</b> Wall and Roof bushings	<b>File name</b> WD2020-12-E
<b>Technical data</b>	Wall and Roof bushings	WD2020-12-E

On request, the bushing could be supplied with a self-earthed test tap



## 6 Nameplate

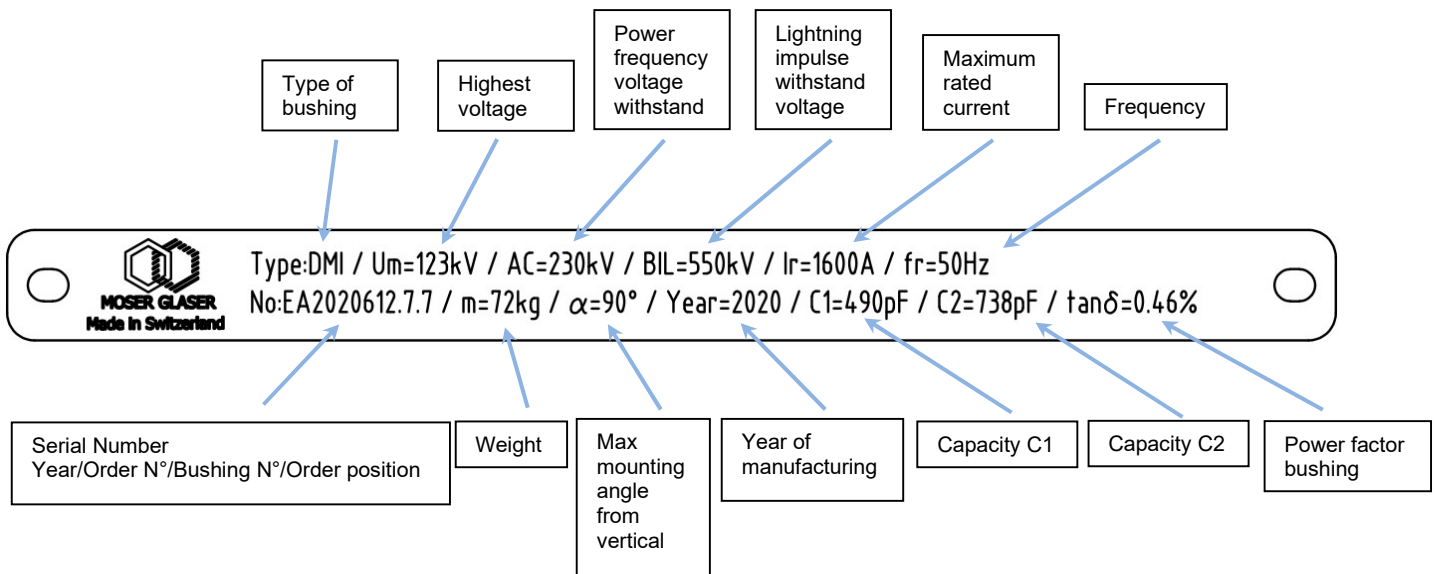

 Current and voltage – our passion	Installation instructions WALL BUSHINGS	
	Topic	File name
Technical data	Wall and Roof bushings	WD2020-12-E

## 7 Maintenance

DURESCA bushings are maintenance free. If however a maintenance inspection is required by the plant operator we recommend the following:

### 7.1 Capacity and Tan Delta measurements (see chapter 5)



#### Caution

Do not work on systems that might be under tension!

### 7.2 Cleaning the silicone sheds

The hydrophobic properties of silicone rubber reduce significantly leakage currents, resulting in an excellent performance in polluted environments. Therefore, there is no need to clean or grease the insulator. Silicone prevents the formation of conductive paths which lead to flashovers, line outages or erosions on the insulator.



#### In case of exceptional severe site conditions :

The insulator can be cleaned manually with soap/water and soft cloth. No oil or detergent should be used. Silicone rubber retains its hydrophobicity after washing.



#### In case of contamination of silicone by oil:

We recommend using Acetone, Isopropyl alcohol or White spirit. This solvent should be used together with a clean cloth to remove the oil from the surface of the insulator.

If done right after the pollution the Silicone rubber will retrieve its form and properties.

### 7.3 Recycling the bushing

The bushings are made with following components:

- Central tube or conductor made of aluminium or copper
- Active part made of resin impregnated paper or synthetic with aluminium foils.
- Flange made of aluminium
- Insulator made of silicone
- Screws, bolts, pins, washer made of stainless steel or aluminium.

As most of these parts are fixed together, we preconize to cut the bushing in several parts. None of the bushings contains any liquids.

Homepage	Created	Released	Revision	Page
www.mgc.ch	GBI 11.06.2024	SMU 11.06.2024	A	19/20

	Topic	File name
Technical data	Wall and Roof bushings	WD2020-12-E

Find our installation instructions on our website

[www.mgc.ch](http://www.mgc.ch)

or by flashing the QR Code

